

Mounting and Operating Manual

CeaGuard 48

target group: for trained and qualified electricians



400 71 343 281 (C)



Mounting and Operating Manual CeaGuard 48

Contents

| | | |
|------|-----------------------------------------------------------------------------------------|----|
| 1 | Important Notes on the Mounting and Operating Manual | 3 |
| 2 | Product Description | 4 |
| 3 | Technical Data | 8 |
| 4 | Application example | 10 |
| 5 | Important Notes on Safety at Work and Safe Operation of CeaGuard 48 | 12 |
| 6 | Intended Use | 13 |
| 7 | Transport, Storage and Disposal | 14 |
| 8 | Mounting | 15 |
| 8.1 | Mounting CeaGuard 48 | 16 |
| 8.2 | connection of the 230V Power Supply | 16 |
| 8.3 | Connection of General Lighting in Conjunction with Switched Permanent Lighting | 17 |
| 8.4 | Connection of Emergency Lighting System | 17 |
| 8.5 | Connection of Potentialfree Signalling Contacts | 18 |
| 8.6 | Connection of a Remote Switch | 18 |
| 8.7 | Connection of a CEAG F3 Remote Indicating Unit | 18 |
| 8.8 | Connection of a CEAG 3-Phase Monitoring Unit | 18 |
| 8.9 | Connection of a CEAG Controllers CG 48 | 19 |
| 8.10 | Completing Mounting Work | 19 |
| 9 | Commissioning | 20 |
| 9.1 | Checking all Connections | 21 |
| 9.2 | Insulation Testing | 21 |
| 9.3 | Switching on CeaGuard 48 | 22 |
| 9.4 | Check Programming | 22 |
| 9.5 | Perform Function and Duration Test | 22 |
| 10 | Operation of CeaGuard 48 | 22 |
| 11 | Programming of CeaGuard 48 | 23 |
| 11.1 | Changing Operating Modes Non-Permanent/Permanent Light | 24 |
| 11.2 | Delete an Emergency Lighting Circuit (Switch off the Circuit) | 24 |
| 11.3 | Enter Number of Luminaires of an Emergency Lighting Circuit | 55 |
| 11.4 | Query Device Data (Settings of CeaGuard 48) | 25 |
| 11.5 | Programming of Function Menus | 26 |
| 12 | Troubleshooting and Remedial Action | 28 |
| | Position Planes | 32 |

1 Important Notes on the Mounting and Operating Manual

Mounting work must only be carried out by skilled electrical personnel (see DIN VDE 0105 Part 1; the Accident Prevention Rules VBG 4 of the (German) Trade Workers' Compensation Association (Hauptverband der gewerblichen Berufsgenossenschaften) or equivalent provisions and guidelines applicable in the country where the lighting system is installed and operated). Other persons may perform the work described in this manual only if

- they have been expertly instructed and trained,
- their tasks and activities have been accurately defined and understood,
- the work is carried out under the supervision of expert electrical personnel.

Aside from important notes on safety the following is to be observed when working with this operating manual:

All important notes are provided with an attention-attracting graphical symbol and an appropriate identifier (eg Note). These catchwords allow risks or damage to be assessed that may arise when disregarding the instructions.

 **Note:** indicates important tips and advice in connection with handling or manipulating the appliances or plant units described.

Attention! draws attention to dangerous situations that may result in damage to machinery or plant units as well as damage to the environment.

Warning! draws attention to dangerous situations that may result in personal injuries or major damage to machinery or plant units as well as major environmental damage.

Danger! draws attention to dangerous situations that may result in life-threatening personal injuries or most serious damage that consequentially may endanger persons or the environment.

Moreover, when using this mounting and operating manual observe the following:

 **Warning!** The figures and elementary diagrams in these mounting and operating instructions sometimes serve the sole purpose of providing elucidation on the subject matter described.

Wherever

- dimensionally true work is to be performed or
 - precise drawings or circuit diagrams tailored to local needs are required,
- the drawings and diagrams especially prepared for the lighting system must be strictly adhered to.**

 **Note:** Various figures and circuit diagrams contained in this mounting and operating manual refer to a polyphase operation.

Such a polyphase operation may not or only conditionally be permitted in some countries. Therefore, make sure to observe the guidelines and standards applicable in the country where the plant is installed and operated.

In the event a polyphase operation is not at all or only conditionally allowed, observance of the applicable national rules and regulations is to be viewed as a prerequisite in the sense of the Intended Use Paragraph (see „6 Intended Use“).

Warning! Only perform work for which you have been adequately qualified and specifically trained in the framework of local operational needs!

Mounting and Operating Manual

CeaGuard 48

2 Product Description

CeaGuard 48 serves for the battery-backed control and emergency supply of an emergency lighting system.

In the section „4 Application Example“ such a safety system is described in some detail.

Up to four circuits of a general lighting system can be linked with up to four emergency lighting circuits. For this purpose, use the switching inputs that are allocated to the relevant outputs via programming.

Note:
Since CeaGuard 48 is an important component within a facility's security system, any planning, commissioning and programming activities have to be performed by experts perfectly familiar with the related safety equipment and systems.

The switching behavior of CeaGuard 48 is determined by programming. CeaGuard 48 is capable of operating in the following modes:

- Non-Permanent Mode**
The luminaires of the emergency lighting system are switched on
 - if the general lighting fails due to the power supply being interrupted,
 - when functional or operating duration testing has been activated manually or automatically.
- Permanent Mode**
The luminaires of the emergency lighting system are switched on
 - during normal mains operation as well as
 - if the general lighting fails due the power supply being interrupted,
 - when functional or operating duration testing has been activated manually or automatically.
- Switched Permanent Mode**
The luminaires of the emergency lighting system are switched on
 - during normal mains operation and when general lighting has been switched on
 - if the general lighting fails due to the power supply being interrupted,

- when functional or operating duration testing has been activated manually or automatically.

CeaGuard 48 has been designed and manufactured in conformity with the following EU guidelines:

- Low-voltage guideline 73/23/EWG, as amended by guideline 93/68/EWG
- Guideline 89/336/EWG on electro-magnetic compatibility

Details of national (DIN-), European (EN-) and international (IEC-) standards complied with are included in the unit's CE Statement of Compliance.

The following CeaGuard 48 versions are available:

- A: Battery 24 Ah / Type of enclosure IP20
- K: Battery 24 Ah / Type of enclosure IP55
- M: Battery 48 Ah / Type of enclosure IP55
- L: Battery 65 Ah / Type of enclosure IP55

Additional information is provided under „3 Technical Data“ and in CEAG Manual „Safety Luminaires and Safety Lighting Systems“.

Two maintenance-free 12V batteries (or four in case of the 48Ah version) are used to power the emergency lighting system in the event the normal power supply system is on failure.

During normal operation CeaGuard 48 monitors the batteries' charging condition and, whenever needed, performs careful battery charging according to the I/U characteristic.

The following supplementary functions can be used with CeaGuard 48 (see „4 Application Examples“):

- Interrogation of CeaGuard 48's potential-free signalling contacts
- Connection of a remote switch (eg designed as key-operated switch)
- Connection of a CEAG F3 remote indicator unit (with key-operated switch)
- Connection of a CEAG 3-phase monitoring unit for the 230V supply system
- Connection of a CEAG controller type CG 48
- Connection of a CEWA GUARD CGP monitoring unit

Mounting and Operating Manual

CeaGuard 48

- ❑ Interrogation of CeaGuard 48's potential-free signalling contacts:
Via 3 signalling contacts the operating state of CeaGuard 48 can be detected and, for example, indicated in a plant control center. The maximum load rating of the connections for these signalling contacts is 24 V AC/DC and 1 A.
The control voltage must be available from an external voltage source. The maximum line length is 1000 m.
In section „4 Application Example“ (Fig. 4) a table is included that summarizes the switching states of the contacts indicative of the respective operating state of CeaGuard 48.
 - ❑ Connection of a remote switch:
CeaGuard 48's emergency lighting operation can be switched on/off via an external switch (eg key-operated switch arranged on a central plant control station).
When enabled (switched on) CeaGuard 48 performs a function test (see „9 Commissioning“).
 - ❑ Connection of a CEAG F3 remote indicator unit:
This device combines a status indication via the signalling contacts of CeaGuard 48 with a remote switching function designed as key-operated switch.
Messages indicated:
 - Plant ready
 - Battery operation
 - Plant failureThis F3 remote indicating unit can be provided with a maximum line length of 1000 m. Further details can be taken from the technical documentation of the F3 remote indicator and CEAG Manual „Safety Luminaires and Safety Lighting Systems“.
 - ❑ Connection of a CEAG 3-phase monitoring unit for the general supply system:
A 3-phase monitoring system is shown in Fig. 4 in the „4 Application Example“ Chapter. Via a 24V loop (max. line length 2000 m) CeaGuard 48 is linked to two 3-phase monitoring units. CeaGuard 48 will process „24V loop interrupted“ as a „fault“. In the event of fault signalling CeaGuard 48 changes the system over to the „Emergency Lighting“ mode.
Such a 3-phase monitoring is compulsory if CeaGuard 48 is operated in the „Non-Permanent“ or „Switched Permanent“ modes.
 - ❑ Connection of a CEAG controller type CG 48:
On the LC display of the controller the current state of the lighting plant is indicated (and can be printed if a printer has been hooked up).
Up to 32 CeaGuard 48 can be monitored by one controller.
CEAG controller CG 48 is intended for operation in distribution boards and switching cabinets.
Further details can be taken from the respective controller's technical documentation and CEAG Manual „Safety Luminaires and Safety Lighting Systems“.
 - ❑ Connection of a CEWA GUARD CGP monitoring unit:
A total of 8 x 32 devices/substations can be connected to one CGP unit.
Via a phone or fax modem and a V24/RS232 interface status messages and commands can be transmitted (eg to a facility's central control and indicating console (ZLT) or personal computer) for further processing.
Further details can be taken from the technical documentation of the CGP used and CEAG Manual „Safety Luminaires and Safety Lighting Systems“.
- i Note:**
In the Federal Republic of Germany a remote indicating system must be mounted on a central plant control station according to VDE 0108.
Make sure to observe any national regulations ruling in the country where the lighting system is to be operated.

Mounting and Operating Manual

CeaGuard 48

CeaGuard 48 primarily consists of the following components and functional groups:

- | | | |
|-------------------------------------------------|---------------------------------------------------------------------------------------------------|----------------------------------------------------------------------------------------------------------------------------------------|
| 1 Enclosure | 6 Motherboard (mimic diagram/LEDs) | 10 Status LCDs for mains operation for battery operation for overload/fault |
| 2 Flange plate (for cable penetration) | 7 LC display | 11 Operation indicating LEDs for mains operation (11a) or emergency lighting (11b) of the individual emergency light circuits |
| 3 Front door | 8 Function buttons | 12 Miniature fuses (observe different types!) |
| 4 Interface module | 9 Compartment for two 12-V batteries (or four batteries in the IP55 enclosure/48Ah version) | |
| 5 Miniature fuses (observe different types!) | | |

Fig. 1 : Equipment View (CeaGuard 48 with 24-Ah battery set in IP20 enclosure)

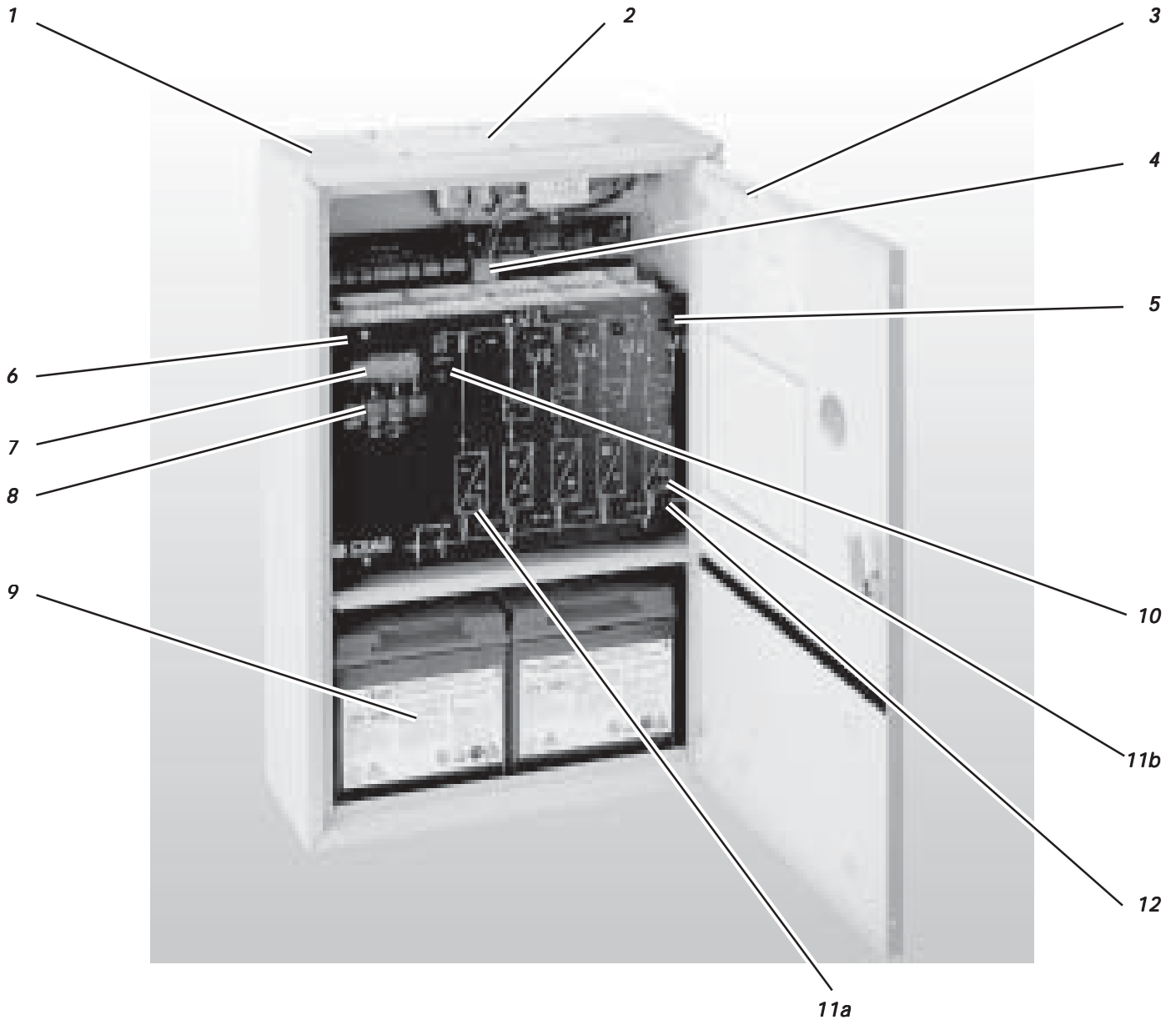

Mounting and Operating Manual

CeaGuard 48

Fig. 2: IP20 Enclosure
(Dimensions in mm)

Depth:
160

Fig. 3: IP55 Enclosure
(Dimensions in mm)

Depth:
350

Attention!

When planning the equipment and during subsequent operation of CeaGuard 48 make sure that

- ❑ **the unit is sufficiently cooled (on this issue see operating temperature requirements in „3 Technical Data“);**
- ❑ **the ambient conditions are met with respect to type of enclosure and class of protection requirements (see „3 Technical Data“);**
- ❑ **only 220 V AC/DC lights of CEAG Sicherheitstechnik GmbH are connected to the emergency lighting circuits of CeaGuard 48; the line length from the unit to the last luminaire in the circuit does not exceed 500m!**
- ❑ **the batteries used for emergency operation comply with the technical specifications applicable to CeaGuard 48 (see „3 Technical Data“);**
- ❑ **the batteries included in the supply are not stored for a period exceeding three months without being charged!**

All connecting leads are run into the enclosure of CeaGuard 48 through bores in the flange blanking plate (Fig. 1, Item 2). The respective entry points or any unused bores are sealed off with M20 plastic plugs included in the supply.

All connections within the enclosure are made via the screw terminal blocks of the connection interface (Fig. 1, Item 4).

The following components are mounted on the motherboard (Fig. 1, Item 6):

- ❑ A block diagram with check lights indicating active lighting circuits (Fig. 1, Items 11a and b)
 - for the circuits of the general lighting system (11a) and
 - for (up to four) circuits of the emergency lighting (11b).
- ❑ An LC display (Fig. 1, Item 7)
- ❑ Four function buttons (Fig. 1, Item 8)
- ❑ 3 status LEDs (Fig. 1, Item 10) indicating
 - mains operation
 - battery operation
 - overload/malfunction
- ❑ 2 x 5 miniature fuses (Fig. 1, Items 5 and 12)

The battery compartment is located below the motherboard (Fig. 1, Item 9).

Mounting and Operating Manual

CeaGuard 48

3 Technical Data

Terminals and Connections

| | |
|--------------------------------------------------------------------|---------------------------------------------------------------------------------------------------------------------------------------------------------------------------------------------------|
| Battery connecting leads | provided in the battery compartment |
| Terminals L, N, PE | for 230V voltage supply line cross section 1.5 ... 2.5 mm ² |
| Terminal pairs (L'1, N'1) ... (L'4, N'4) | for 230V contact interrogation of the operating status of general lighting circuits |
| Terminal pairs (11,12) ... (31,32) identified by switch symbol! | for 3 potential-free signalling contacts for the operating status of CeaGuard 48 max. 24 V AC/DC external interr. voltage max. 1 A for each signalling contact |
| Terminal pair 24V (+ and -) | for 24V voltage supply only for CEAG F3 remote indication! |
| Terminal strip (E, G, A) | eg for a CEAG Controller CG48 max. line length 6000 m (with 2.5 mm ²) |
| Terminal pairs (S1, S2) and (S3, S4) | for 24V monitoring loops eg for a remote switch and a CEAG 3-phase monitoring system max. adm. line length 2000 m each with a line cross section of 1.5 mm ² |
| Terminal strips (11, 12, PE) (41, 42, PE) | for voltage supply of max. 4 emergency lighting circuits each with max. 12 CEAG lights, 4 ... 8 W line cross section 1.5 ... 2.5 mm ² max. line length 500 m (per circuit) |

Operating and Indicating Elements

| | |
|----------------------------------------------------------|---------------------------------------------------------------------------------------------------|
| 1 LC display (Fig. 1, Item 7) | for indications and messages during operation and programming of the CeaGuard 48 |
| 4 function buttons (Fig. 1, Item 8) | for the programming of CeaGuard 48 |
| 3 status LEDs (Fig. 1, Item 10) | for mains operation for battery operation for overload/malfunction |
| 5 operation-indicating LEDs (Fig. 1, Items 11a and b) | for indication of mains operation or battery operation of the 4 emergency lighting circuits |

Batteries for Emergency Operation

| | |
|---------------------------|-------------------------------------------------------------------|
| CeaGuard 48 Version 24 Ah | 2 x 12 V / 24 Ah (Pb) Ident. No./Order No. 400 71 341 097 (1x) |
| CeaGuard 48 Version 48 Ah | 4 x 12 V / 24 Ah Ident. No./Order No. 400 66 041 179 (4x) |
| CeaGuard 48 Version 65 Ah | 2 x 12 V / 65 Ah Ident. No./Order No. 400 66 041 418 (2x) |

Mounting and Operating Manual

CeaGuard 48

Voltage Supply (Unit)

| | |
|--------------------------------------|--------------------------------------------------------------------------|
| Supply voltage | 230 V AC (50/60 Hz) |
| Power absorbed | 65 W (electronic and control system) plus emergency lighting circuits |
| Power absorbed in charging operation | 130 W |

Voltage Supply (Lights)

| | |
|--------------------------------------|---------------------------------------------------------------------------------|
| General lighting | 230 V AC |
| Emergency lighting | 220 V DC |
| 24-Ah version: 2 x 12 V / 24 Ah | 1 hour rated operating time at 14.4 A 3 hours rated operating time at 6.4 A |
| 48-Ah version: 2 x (2x 12 V / 24 Ah) | 1 hour rated operating time at 17.0 A 3 hours rated operating time at 12.8 A |
| 65-Ah version: 2 x 12 V / 65 Ah | 1 hour rated operating time at 17.0 A 3 hours rated operating time at 17.0 A |
| max. supply voltage | 320 V A |
| max. transformer current/output | $I_B = 4.25 \text{ A}$ |

Enclosure

| | | |
|------------------------------------------------------------|---------------------------------------------------------------------------------------------------------------------------------------------------------------------|-------------------------------------------------|
| Construction | Full metal enclosure with front door | |
| Color | RAL 7032 | |
| Dimensions | IP20 enclosure | 600 x 400 x 160 mm (H x W x D) |
| | IP55 enclosure | 800 x 600 x 350 mm (H x W x D) |
| Weight (unit with batteries) | 24Ah / IP20 enclosure | appr. 29 kg |
| | --- | --- |
| | 65Ah / IP55 enclosure | appr. 85 kg |
| Type of enclosure | IP20 enclosure | IP 20 as per DIN EN 60 529 (built-in condition) |
| | IP55 enclosure | IP 55 as per DIN EN 60 529 (built-in condition) |
| | electronic system | IP 54 as per DIN EN 60 529 |
| | batteries | IP 43 as per DIN EN 60 529 |
| Class of protection | 1 (for all versions) as per DIN EN 60 598 (built-in condition) | |
| Admissible temperature range | storage | - 20 °C + 40 °C |
| | operation | - 5 °C ... + 35 °C |
| Admissible ambient conditions during storage and operation | see a.m. type of enclosure and protection class as regards safeguarding to prevent contact with live components and the ingress of dust, foreign bodies or moisture | |

Mounting and Operating Manual

CeaGuard 48

Specifications

Batteries for the Standby Power Supply

CEAG can supply battery cabinets in a range of sizes and component configurations. We use low-maintenance batteries according to EUROBAT; these batteries have a service life in excess of 10 years if treated properly. Depending on their design and version, these CEAG approved batteries will meet the requirements which must be satisfied for emergency lighting systems that are mandatory under building regulations in the Federal Republic of Germany (EN 50272 and EN 60896-2).

CEAG Standard Battery Cabinets

| | |
|-------------------------------------------|----------------------------|
| Battery capacity in the range from | 24 to 390 Ah ¹⁾ |
| Rated voltage | 216 V DC |
| Dimensions (W x H in mm) | various ²⁾ |
| Weight (depending on type, approx. in kg) | various ²⁾ |

CEAG Compact Battery Cabinets

| | |
|------------------------------------|----------------------------|
| Battery capacity in the range from | 5.5 to 80 Ah ¹⁾ |
| Rated voltage | 216 V DC |
| Dimensions (W x H in mm) | various ²⁾ |
| Weight (approx. in kg) | various ²⁾ |

CEAG Battery Racks

| | |
|------------------------------------|----------------------------|
| Battery capacity in the range from | 24 to 390 Ah ¹⁾ |
| Rated voltage | 216 V DC |
| Dimensions (W x H in mm) | various ³⁾ |
| Weight (approx. in kg) | various ³⁾ |

¹⁾ Battery capacities over 130 Ah are achieved by connecting several battery sets in series.

²⁾ See CEAG installation instructions for battery cabinets (300 80 001 441)

³⁾ See CEAG installation instructions for battery racks (300 80 001 442)

Operating temperature

The ideal operating temperature is 20 °C. Lower temperatures reduce the available capacity. Higher temperatures reduce battery service life.

The specifications are for the nominal temperature of +20 °C.

Please absolutely observe our installation instruction for battery cabinets 300 80 001 441 and battery racks 300 80 001 442.

4 Application Example

Fig. 4 shows a general and emergency lighting system version monitored and operated via CeaGuard 48.

- ❑ The emergency lighting circuits are connected to terminal strips (11, 12, PE) ... (41, 42, PE).
A maximum of 4 emergency lighting circuits can be realized, each accommodating max. 12 lights. 
Circuit 3 for the emergency lighting system has been divided into two parallel sub-circuits.
- ❑ In addition to CeaGuard 48 some modules are used for the phase monitoring of the general supply mains.
These modules (CEAG order No. 40071 343 430) are mounted in the distribution board and serve to signal to CeaGuard 48 faults in the 230V voltage supply system.
The signalling lines are hooked up to terminals S3 and S4 in a 24V monitoring loop.
For example, a malfunction would be signalled to CeaGuard 48 if one of the monitored phases fails.
During mains operation
 - switch S1 will switch on/off the general lighting system;
 - the emergency lighting system is switched on/off in conformity with the operating mode selected (non-permanent, permanent or switched permanent lighting);
 - CeaGuard 48 will monitor the charging state of the batteries for emergency lighting. When discharged the respective batteries will be re-charged by CeaGuard 48.

If CeaGuard 48 detects a power supply failure it changes the system over to battery operation.
The circuits of the emergency lighting system connected to CeaGuard 48 are supplied with power from the batteries of CeaGuard 48 until the power supply system fault has been rem-

edied (see „3 Technical Data“ for duration and capacity of the emergency power supply).

- ❑ Moreover, Fig. 4 shows the connection of a CEAG F3 remote interrogation device with integrated remote switch.
This device is operated via the 24V power supply system of CeaGuard 48. This internal voltage supply of CeaGuard 48 is to be exclusively used for this particular purpose!
Terminal pairs (11, 12) ... (31, 32) have been identified with switch symbols on the interface module (Fig. 1, Item 4) to make sure they are not confused with terminals on the terminal strips intended for the emergency lighting system!
- ❑ In case other indicators (eg signalling lamps) are to be hooked up to terminal pairs (11, 12) ... (31, 32), an external 24V power supply must be made available for contact interrogation. Each signalling contact of CeaGuard 48 can be loaded at max. 1 A. Information about the switching position of the signalling contacts and the operating state of CeaGuard 48 can be taken from the table on the next page.
- ❑ A data line can be connected to terminal strip (E, G, A). Via this data line a CEAG controller CG 48 or a central monitoring unit CEWA GUARD CGP can be operated. Details can be seen from the manufacturer's documentation and CEAG Manual „Safety Luminaires and Safety Lighting Systems“.



Note:

The proper functioning of the overall system depends on the correct installation and programming of CeaGuard 48.

Please make sure that personnel involved in planning, mounting and programming is duly qualified for its work.

Mounting and Operating Manual CeaGuard 48

Fig. 4: Application Example of CeaGuard 48 with CEAG 3-phase Monitoring and CEAG F3 Remote Indication

| Possible coding of indications via signalling contacts on terminal pairs | (11,12) | (21,22) | (31,32) |
|--------------------------------------------------------------------------|---------|---------|---------|
| Mains operation | open | closed | open |
| Mains failure | open | open | closed |
| Charging fault | closed | open | open |
| Transformer fault | closed | open | open |
| Sumcheck error | closed | open | open |
| Flat-battery monitor | closed | open | open |
| Function test | open | open | closed |
| Operating duration test | open | open | closed |

Possible switching commands via a remote switch on (S1,S2)

| |
|----------------------------|
| ON: |
| Emergency function enabled |
| OFF: |
| CeaGuard 48 is blocked |

Line cross sections and max. line length with EGA data lines

| Cross sect. in mm ² | Length in m |
|--------------------------------|-------------|
| 0.5 | 1000 |
| 1.0 | 2000 |
| 1.5 | 2500 |
| 2.5 | 6000 |

5 Important Notes on Safety at Work and Safe Operation of CeaGuard 48

Warning!

This unit forms part of the emergency and general lighting system and as such is an important safety component of a building or operating location.

Any unauthorized or makeshift (Inexpert) work carried out on the system may result in a failure of the general or emergency lighting installation and thus cause

- significant danger to persons,**
- significant damage to machinery and plant units,**
- malfunctions and interruption of the production sequence.**

After the unit has been mounted, connected and commissioned only the following work is required during normal operation:

- Monitoring and logging of the equipment function
- Safeguarding actions in the case of malfunctions
- Carrying out inspections and safety checks prescribed by law and regulations



Notes:

- Observe the national legislation and guidelines with respect to the design and control of a plant forming part of general and emergency lighting systems.
- Observe the national legislation and guidelines with respect to inspections and safety checks (eg for function and operating duration testing).

Organization and monitoring of this work is the duty of the lighting system operator. The following is to be laid down in writing and the relevant documents must always be available:

- Type and scope of the above mentioned work
- Documentation of the results of the work

- Responsibility and authorization regarding the work to be performed
 - Who is allowed to perform a certain task?
 - Who has to monitor the work performed?
- Duty to alert (eg in case of faults or function testing)
- Organizational measures when work is carried out on the lighting system. This may include, inter alia:
 - Information and reporting duty regarding start, duration and end of the work concerned
 - Safety measures to be taken during the work (eg reserve lighting, disconnecting the power supply, safeguards to prevent accidental restarting)
 - Protection and safety equipment for the personnel carrying out work on the plant (eg suitable working clothes and PPE)
 - Protection and safety measures to rule out danger caused by neighboring plant units (eg providing safety fences, barriers, securing traffic routes)

Inspections and safety checks have to be performed exclusively by authorized expert staff that must also prepare the required documentation (to satisfy national legislation and rules).



Note:

If the lighting system or the programming of CeaGuard 48 requires modification or in the event of safety checks to be performed, please contact the respective branch of CEAG or consult experts of authorized institutes.

Moreover, observe what has been said regarding target group and use of this Operating Manual in Chapter „1 Important Notes on this Mounting and Operating Manual“ and in „6 Intended Use“.

Mounting and Operating Manual CeaGuard 48

6 Intended Use

CeaGuard 48 is meant to monitor and control a lighting system comprising general and emergency lighting units. CeaGuard 48 operates under program control. Programming must exclusively be carried out by expert personnel having special knowledge of statutory and technical fundamentals governing the erection and operation of a lighting system.

CeaGuard 48 has been designed and built to reflect latest the technical rules governing system safety.

Nevertheless, danger may arise during plant operation

- to personnel if the safety instructions are disregarded,
- if the unit is used for other than the intended purpose.

Therefore, operate the unit and any system components attached only when in perfect technical condition and observe

- the safety and danger notes included in this mounting and operating manual,
- work procedures and safety instructions prescribed by the plant Operator,
- the installation and operating data listed in Chapter „3 Technical Data“ and in CEAG Manual „Safety Luminaires and Safety Lighting Systems“.

Malfunctions that may impede the functioning or safety of the plant must at once be reported to the respective level of the plant management and have to be eliminated without delay.

The working and safety rules and regulations are to be observed as laid down in this mounting and operating manual and furthermore as they arise from

- organizational measures initiated by the Plant Management as described under
 - „1 Important Notes on this Operating Manual“,
 - „5 Important Notes on the Safety at Work and Safe Operation of CeaGuard 48“

as well as from the general and specific accident prevention rules and regulations.



Note:

CEAG will not assume any warranty or liability for damage or consequential damage occurring as a result of

- using the system for other than the intended purpose,
- disregarding rules and regulations governing the safe operation of the system,
- unauthorized or inexpert modifications to
 - connections and settings of the unit, or
 - the unit's programming,
- operating devices or device groups in conjunction with CeaGuard 48 that are unsuited or not permitted.

Attention!

In addition, be sure to observe all laws, standards and guidelines applicable in the country where the CeaGuard equipment is mounted and operated.

7 Transport, Storage and Disposal

The batteries are supplied separately. They will only be installed and connected when the unit is mounted.

As regards transport and storage of the batteries please follow the instructions issued by the battery manufacturer.

Attention!

- Batteries for emergency operation must exclusively be stored for a period not exceeding three months without being charged!
- In case the power supply to CeaGuard 48 is interrupted for more than three days the battery circuit must be disconnected.
This work must only be performed by trained electrical personnel.

The following must be observed when handling and storing CeaGuard 48:

- Always handle and store the unit in upright position (see markings on the package or make sure that flange blanking plate with cable glands is on top).
- Observe the technical specifications governing ambient conditions when handling and storing CeaGuard 48. The storage location should be dry and clean. Avoid the ingress of dust and moisture and rule out condensate formation due to moisture during transport and storage. Further details regarding admissible ambient temperatures, type of enclosure, and protection class can be seen from „3 Technical Data“.

Notes:

- Packing materials are not to be viewed as garbage but are valuable substances that have to be processed by suitable recycling measures to render them suited for reuse*).
- Please follow any national guidelines and provisions governing the disposal of packing material.
- Batteries and electronic components contain substances that cause health and environmental risk and damage if not disposed of expertly.
- Therefore, strictly observe the national guidelines and provisions governing the disposal of used batteries and electronic scrap.

*) The recycling of packing material is carried out via the company of INTERSEROH.

Contract No. 85405 concluded with INTERSEROH applies.

All INTERSEROH collecting locations are obliged to dispose of CEAG packings free of charge.

This ensures that all registered packings are utilized in terms of material exploitation with the requirements of the Packing Ordinance being fully met.

8 Mounting

All the mounting work described here is based on the diagrams and drawings prepared for the lighting system. These diagrams and drawings must take into account the actual circumstances relating to the technical solution involving the use of CeaGuard 48 within a general and emergency lighting system. They have to be prepared by experts in line with applicable electrotechnical guidelines and standards.

Warning!

- Work on the 230V mains and laying of connection, signalling, and control cabling must only be carried out by skilled electrical personnel.
- Laying of connection, signalling, and control lines must exclusively be performed in conformity with applicable guidelines and standards of electrical engineering (eg DIN VDE 100 standards series).
- In addition please observe all national guidelines and provisions ruling in the country where the plant is erected and operated.

Attention!

Only lights operating on 220V AC/DC furnished by CEAG Sicherheitstechnik GmbH must be connected to CeaGuard 48!
The line length from the unit to the last luminaire in the circuit must not exceed 500 m!

Attention!

The batteries included in the supply must only be stored for a period not exceeding three months without being charged!
In case the power supply to CeaGuard 48 is interrupted for more than three days the battery circuit must be disconnected.

Danger!

Take all measures required to warrant safety at the workplace!

- Observe all applicable technical rules and standards relating to safety at work.
- Observe the instructions and notes included in this manual.
- Observe any specific guidelines and instructions issued by the plant Operator.
- Observe any reporting and notifying instructions when starting, carrying out and having completed the work.
- If you participate in the mounting work as third-party employee make sure the plant Operator provides sufficient familiarization informing you of any local requirements to be observed. Such a familiarization shall cover operational sequences as well as info about existing machinery and plant.
- Take into account effects on neighboring plant units when working on the installation of the CeaGuard system.
- If necessary, consult with the plant Operator's authorized skilled staff!
- Before starting with your work disconnect all plant units you will work on from the mains. When doing this, consider possible effects on other plant units and, having consulted the plant Operator, take any action required. Should it be impossible for important reasons to disconnect systems from the mains, take all measures required to safeguard and secure the respective plant units.
- Any cut-off for safety reasons must be safeguarded to prevent an inadvertent activation/restarting (eg lock or cover switches as necessary).

Mounting and Operating Manual

CeaGuard 48

Fig. 5: Attachment Bores

Drilling template
for
IP20 enclosure

Drilling template
for
IP55 enclosure

Fig. 6: Single-line Diagram of CeaGuard 48 Connected to the 230V Supply System

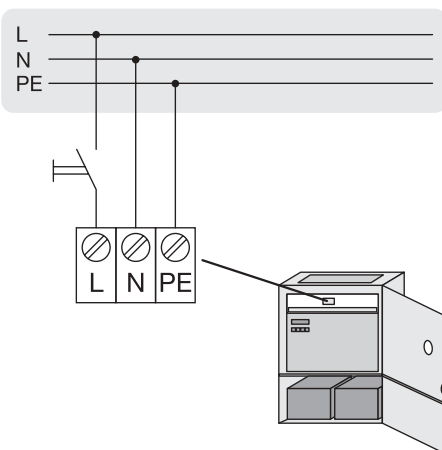

Warning!

- When opening CeaGuard 48 observe ESD protection (electrostatic discharge)!
- Make sure the terminals (poles) of the batteries are correctly connected. Short circuits or wrong polarity may result in electrical shocks endangering persons. Moreover, wrong polarity of the battery may cause damage to the system's electronic components.

Danger!

Before drilling holes for the fixing of CeaGuard 48 or laying connecting leads make sure not to damage concealed lines (eg electrical, gas, hydraulic, or water lines)!

Attention!

Connect the batteries for emergency operation only in the course of initial or re-commissioning work (see „9 Commissioning“). In this way faulty switching can be avoided when CeaGuard 48 is in the process of being installed.

- In case you want to store the batteries in the compartment until the system is commissioned, make sure to insulate battery terminals or battery connecting leads!

8.1 Mounting CeaGuard 48

In the back of the CeaGuard 48 enclosure four (or eight) holes have been provided (see Fig. 5). Use these holes to mount the enclosure on a wall or special suspension structure by means of bolting.

In case batteries are arranged in the battery compartment these have to be removed.

- Drill the holes or prepare the suspension structure to which CeaGuard 48 is to be attached (see Fig. 5a and 5b).
- Bring 48 in mounting position and attach the enclosure by bolting. Use suitable screws and attachment elements for this work.
- Mount the flange blanking plate with openings allowing all connecting leads to be run into the interior of the CeaGuard enclosure.



Note:

CEAG supply includes pre-drilled blanking plates with M20 plastic plugs.

8.2 Connection of the 230V Power Supply

Power is fed to CeaGuard 48 (electronic system and battery charger) from the general 230V mains supply (or via the batteries when in emergency operating mode).

Take note of the adjacent single-line diagram (Fig. 6) and plans and drawings applicable to installation at the plantsite. Observe cross sectional areas of conductors as specified under „3 Technical Data“!

- Install the connecting leads for the 230V power supply between the distribution unit and the general power supply system and CeaGuard 48.
- Connect CeaGuard 48 to the 230V power supply system. For correct terminal assignment (terminals L, N and PE) see single-line diagram on this page (Fig. 6).

Attention!

Do not switch on the power before you have completed all the required laying and mounting activities (see „9 Commissioning“).

Mounting and Operating Manual

CeaGuard 48

Fig. 7: Single-line Diagram Showing General Lighting System Connection

Luminaires of general lighting

8.3 Connection of General Lighting in Conjunction with Switched Permanent Lighting

Power to the general lighting system comes from the general 230V mains supply grid.

Take note of the adjacent single-line diagram (Fig. 7) as well as plans drawings applicable to plantsite installation.

- ❑ Install the connecting leads (one phase L1, the neutral conductor N and the protective earth conductor PE) between the distribution unit of the general 230V supply grid and switch S1 for the general lighting system.
- ❑ Connect the luminaires of the general lighting system as prescribed by the manufacturer.
- ❑ Connect lines L1 and N also to terminals L'1 and N'1 of CeaGuard 48 (transmitting the operating state of the general lighting system to CeaGuard 48 via 230V contact interrogation). As regards cross sectional areas of conductors please observe „3 Technical Data“.

Note: Additional independent circuits of a general lighting system can be connected to the interrogation contacts via terminal pairs (L'2, N'2) to (L'4, N'4). The assignment can be made when carrying out programming of CeaGuard 48 in the framework of commissioning.

- ❑ If applicable, connect additional circuits of a general lighting system to CeaGuard 48.

Warning!

Do not switch on the power to the general lighting system before you have completed all the required laying and mounting activities (in this context see „9 Commissioning“).

8.4 Connection of Emergency Lighting System

Power is fed to the emergency lighting system via CeaGuard 48 (terminal block (11, 12, PE) ... (41, 42, PE)).

Observe the adjacent single-line diagram (Fig. 8) as well as plans and drawings applicable to plantsite installation work.

Furthermore, observe with respect to each circuit information under „3 Technical Data“ as regards number of emergency luminaires, maximum admissible line length and appropriate conductor cross sections.

- ❑ Lay power supply connection leads between terminal blocks (11, 12, PE) ... (41, 42, PE) of CeaGuard 48 and the respective circuits 1 ... 4 of the emergency lighting system.
- ❑ Connect the emergency lighting system luminaires as prescribed by the manufacturer.
- ❑ Set the addresses (1 ... 12) for the luminaires of an emergency lighting circuit. For this purpose, proceed as prescribed in the Technical Documentation of the luminaires.
- ❑ Connect the supply leads for the emergency lighting circuits to terminal blocks (11, 12, PE) ... (41, 42, PE) of CeaGuard 48.

Warning!

Do not switch on the power to the emergency lighting system before you have completed all the required laying and mounting activities (in this context see „9 Commissioning“).

Fig. 8: Single-line Diagram Showing (up to Four Lines) of the Emergency Lighting System

max. 12 luminaires

max. 12 luminaires

Mounting and Operating Manual

CeaGuard 48

Fig. 9: Single-line Diagram Showing Connection of Potential-free Signalling Contacts

8.5 Connection of Potential-free Signalling Contacts

Connection is to be made to marked terminal pairs (11, 12) ... (31, 32) of CeaGuard 48 (observe the symbols for switching contacts on the interface module of CeaGuard 48).

Follow the manufacturer's instructions included in the Technical Documentation as applicable to the indicating elements on the control panel.

Information on contact position and assigned messages of the operating status of CeaGuard 48 is given on page 9 in Fig. 4.

Observe the instructions under „3 Technical Data“ with respect to maximum admissible line length and conductor cross sections.

Attention!

An external voltage source must be provided for the indicating elements.

The (internal) signalling contacts of CeaGuard 48 are designed for a maximum load of 24 V AC/DC as well as 1 A.

- ❑ Connect the signalling contacts as per
 - the manufacturer's instructions for the external 24V voltage source and for the indicating elements used,
 - the adjacent single-line diagram (Fig. 9),
 - the plans and drawings applicable to plantsite installation.

8.6 Connection of a Remote Switch

Connection is to be made to terminals S1 and S2 of CeaGuard 48.

Observe the instructions in the Technical Documentation as provided by the manufacturer of the remote switch (eg relating to a control station).

Observe the instructions under „3 Technical Data“ with respect to maximum admissible line length and conductor cross sections.

- ❑ Connect the remote switch as per
 - the manufacturer's instructions,
 - the adjacent single-line diagram (Fig. 10),
 - the plans and drawings applicable to plantsite installation.
- ❑ Bridge contacts S1 and S2, if these are not wired.

8.7 Connection of a CEAG F3 Remote Indicating Unit

The unit is to be connected to the following terminals of CeaGuard 48:

- S1 and S2 (remote switch)
- + and – for the 24V voltage supply of CEAG F3 remote indicator and terminals (signalling contacts!) 32 (signal „Battery operation“)
- 22 (signal „Mains operation“)
- 11 (signal „Malfunction“)

Observe the instructions in the Technical Documentation as provided by the manufacturer of the CEAG F3 remote indicator. Observe the instructions under „3 Technical Data“ with respect to maximum admissible line length and conductor cross sections

Attention!

Terminals + and – on the terminal block must only be used for 24V voltage supply of the CEAG F3 remote indicating unit.

- ❑ When connecting the CEAG F3 remote indicating unit make sure to observe
 - the manufacturer's instructions,
 - the single-line diagram (Fig. 11) on this page,
 - the plans and drawings applicable to plantsite installation.

8.8 Connection of a CEAG 3-Phase Monitoring Unit

A CEAG 3-phase monitoring unit is to be connected via terminals S3 and S4 of CeaGuard 48.

Observe the instructions under „3 Technical Data“ with respect to maximum admissible line length and conductor cross sections.

Fig. 10: Single-line Diagram of a Remote Switch Connection

Fig. 11: Single-line Diagram of an F3 Remote Indicator Connection

Mounting and Operating Manual

CeaGuard 48

Fig. 12: Single-line Diagram Showing Connection of CEAG 3-Phase Monitoring Units



Notes:

- If more than 3 phases have to be monitored, additional devices must be hooked up and connected to the other devices in a 24V loop (see Fig. 12).
- If less than 3 phases have to be monitored by one 3-phase monitoring unit, the remaining inputs of the 3-phase monitoring unit must be bridged.

- When connecting CEAG 3-phase monitoring units make sure to observe
 - the manufacturer's instructions,
 - the single-line diagram (Fig. 14) on this page,
 - the plans and drawings applicable to plantsite installation.
- Bridge contacts S3 and S4, if these are not wired.

8.9 Connection of a CEAG Controller CG 48

The connection is to be made to terminals E, A and G of CeaGuard 48. Observe the manufacturer's instructions in the Technical Documentation for the controller.

- When connecting CEAG controller CG 48 make sure to observe
 - the manufacturer's instructions,
 - the single-line diagram (Fig. 13 and 14) on this page,
 - the plans and drawings applicable to plantsite installation.

8.10 Completing Mounting Work

- Check all the wiring by way of applicable plans and drawings for plantsite installation.
- Make sure that all connections have been securely tightened.
- Bridge any unwired contacts (S1, S2) and (S3, S4) of the 24V monitoring loops.
- Bridge any unwired L contacts of the 3-phase monitoring units installed.
- Fasten the top blanking plate of CeaGuard 48 and close off all openings using the M20 plastic plugs included in the supply.
- Remove all unused cables, insulating and fastening material as well as all tools and packaging material.

Fig. 13: Sample Configuration of a CEAG Controller CG 48 Connection

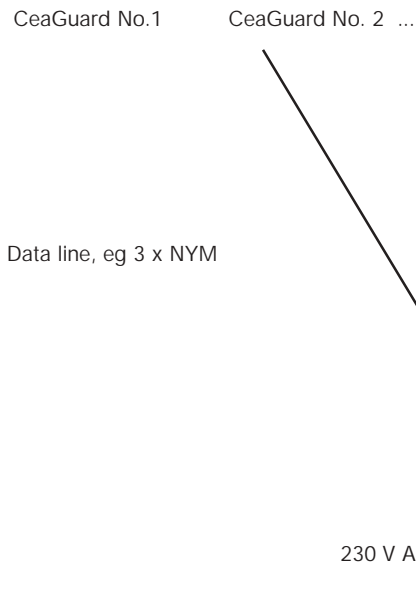

Fig. 14: Terminal Assignment on CeaGuard 48

9 Commissioning

Warning!

- ❑ The lighting installation/system must only be commissioned by expert electrical personnel sufficiently familiar with statutory and technical regulations and provisions governing the erection and operation of lighting equipment.
- ❑ Additionally, observe all laws, standards, and guidelines applicable in the country where the CeaGuard plant is mounted and operated.

Take all measures required to warrant safety at the workplace!

- ❑ Observe all applicable technical rules and standards relating to safety at work.
- ❑ Observe the instructions and notes given in this manual.
- ❑ Observe any specific guidelines and instructions issued by the plant Operator.
- ❑ Observe any reporting and notifying instructions when starting, carrying out and having completed the work.
- ❑ If you participate in commissioning as third-party employee, make sure the plant Operator provides sufficient familiarization informing you of any local requirements to be observed. Such a familiarization shall cover operational sequences as well as info about existing machinery and plant.
- ❑ Take into account effects on neighboring plant units when working on the installation of the CeaGuard system.
- ❑ If necessary, consult with the plant Operator's authorized skilled staff!
- ❑ Before starting with your work disconnect all plant units you will work on from the mains. When doing this, consider possible effects on other plant units and, having consulted the plant Operator, take any action required.

Should it be impossible for important reasons to disconnect systems from the mains, take all measures required to safeguard and secure the respective plant units.

- ❑ Any cut-off for safety reasons must be safeguarded to prevent an inadvertent activation/restarting (eg lock or cover switches as necessary).

For commissioning proceed as follows:

- ❑ Check all connections for completeness and tight seat as per plans and drawings applicable to plantsite installation.
- ❑ Check whether cable entries through flange blanking plate on top of the CeaGuard enclosure are tight to media.
- ❑ Test insulation resistance against the PE conductor.
- ❑ Connect the batteries for emergency operation.
- ❑ Switch on CeaGuard 48.
- ❑ Check proper functioning of the emergency lighting (function and duration testing).

Notes:

- A programming of CeaGuard 48 must be carried out if
 - one or more circuits of the emergency lighting are switched to non-permanent mode,
 - less than 4 circuits of the emergency lighting are connected,
 - less than 12 luminaires are installed in a circuit for emergency lighting purposes,
 - the assignment of general lighting and emergency lighting circuits has to be modified.

Further measures must be taken if one or more CeaGuard 48 units are operated via a control station or if a controller is used. In this case, follow the instructions included in the Technical Documentation relating to these components.

Mounting and Operating Manual

CeaGuard 48

9.1 Checking all Connections

- ❑ To carry out the checks, disconnect the lighting system and CeaGuard 48 from the mains supply!
Safeguard this cut-off measure!
Do not switch on the power supply system before you have been expressly requested to do so in the framework of commissioning.
- ❑ Make sure all connections and lines are provided as called for in the drawings and plans applicable to the lighting system.
- ❑ Check all connections and boltings for tight seating.
- ❑ Make sure all cable entries in the flange blanking plate on top of the CeaGuard 48 are tight to media.

9.2 Insulation Testing

- ❑ To carry out this check, disconnect the power supply to CeaGuard 48 from the mains!
Safeguard this cut-off measure!
Do not switch on the power supply system before you have been expressly requested to do so in the framework of commissioning.

Danger!

Insulation tests must only be carried out between protective conductor PE and phase conductors L1 (L2, L3) as well as N.

- **Test voltage:**
max. 1 kV AC/DC
- **Test current:**
max. 10 mA

- ❑ Disconnect the emergency lighting connections on CeaGuard 48 in the following sequence:
 - Disconnect mains feeder L, N and PE and bridge wires L and N.
 - Disconnect feeder line(s) to the emergency lighting lines and bridge wires 11 and 12.
In the case of further emergency lighting circuits proceed analogously.
- ❑ Carry out insulation tests as shown in Fig. 15 on this page for
 - the connections of the 230V power supply of CeaGuard 48,
 - the feeders of the emergency lighting circuits.
- ❑ Having completed insulation testing
 - bridge terminals L and N on CeaGuard 48 against PE,
 - bridge wires 11 and 12 etc. of the emergency lighting circuits against PE.

This will eliminate residual voltage in the CeaGuard 48 and in active components of the luminaires.
- ❑ Reconnect all disconnected connections.

Fig. 15: Insulation Testing

Mounting and Operating Manual CeaGuard 48

Fig. 16: Connection of Batteries

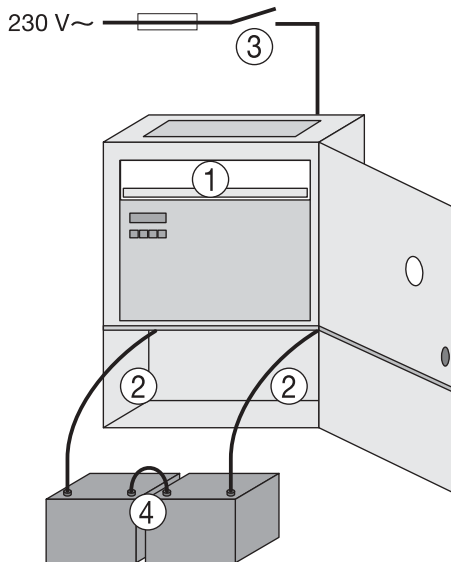
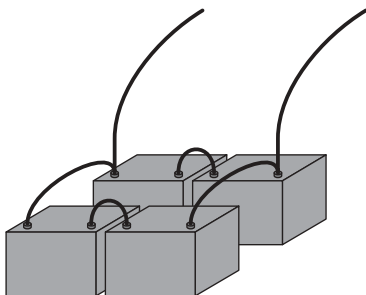

Fig. 17: Interconnection of Batteries for 48Ah Version in IP55 Enclosure



9.3 Switching on CeaGuard 48

Warning!

When connecting the batteries check for correct polarity (red = + and black = -).

Short circuits or wrong polarity may result in electrical shocks endangering persons or cause damage to CeaGuard 48 or batteries.

- Proceed as follows (Fig. 16):
 - 1. Connect mains feeder (may be connected already, see 9.2)
 - 2. Connect batteries:
 - a) Connect red line to the positive pole of one battery.
 - b) Connect black line to the negative pole of the other battery.
 - 3. Switch on mains supply.
 - 4. Connect bridge between the free positive/negative poles of the two batteries.

9.4 Check Programming

- If necessary, check and change the assignment of connected circuits of the general and emergency lighting systems.
- If necessary, check and change the programming of the switching behavior of CeaGuard 48.

9.5 Perform Function and Duration Testing

- Carry out function and operating duration testing for the lighting system as prescribed. Proceed as described under „10 Operation“.



Note

If the duration test shows that the operating duration is less than 2/3 of rated capacity (see „3 Technical Data“), the batteries have to be charged for at least 20 hours. If the duration test then fails again, new batteries must be installed (see VDE 0108 Part 1, Sect. 9.2.2).

10 Operation of CeaGuard 48

CeaGuard 48 is operated via buttons on the mimic diagram (Fig. 4, Item 8).

These buttons perform the following basic functions:

- Button 1: „Menu“
- Button 2: „TEST“
- Button 3: „Operating duration TEST“
- Button 4: „Enter“

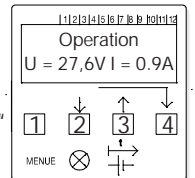

In programming and indicating mode (switched on by pressing the „Menu“ button) the function of buttons 2 and 3 changes:

- Button 2: „forward“
- Button 3: „back“

In the descriptive text, a button to be pressed is shown in parentheses, eg <Menu>.

In the event of a fault indication proceed as outlined under „12 Troubleshooting and Remedial Action“.

- Function test is initiated by pressing the <TEST> button. The luminaires of the emergency lighting circuits are checked for proper functioning. The unit switches over to battery operation (LED illuminated). The message „Function test!“ is shown in the display together with current values of voltage and current. After one minute the unit automatically returns to the basic display as shown above, otherwise a fault message may appear.

- Duration test is initiated by pressing the <Duration TEST> button. The unit switches over to battery operation (LED illuminated) and the message „Duration test“ is shown in the display together with current voltage and current values. After one minute the voltage and current values are replaced by a battery capacity indication in minutes (pressing <Menu> causes current values to reappear). After 1 minute, duration testing can be cancelled by pressing <Enter>.

Mounting and Operating Manual CeaGuard 48

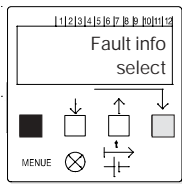

Batteries Ok
continue

Luminaires Ok
continue

Operation
U = 27,6V I = 0.9A

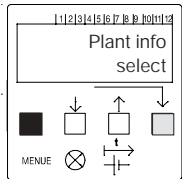

No. test cycl. = X
continue

BT time > X
min
continue

FT in x T y S
continue

BT in 365 days
continue

Version ZXXX.F
continue

Operation
U = 27,6V I = 0.9A

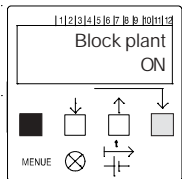

Plant blocked
U = 27,6V I = 0.0A

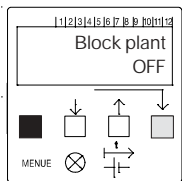

Operation
U = 27,6V I = 0.9A

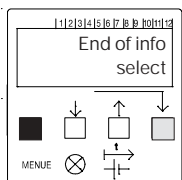

Operation
U = 27,6V I = 0.9A

- Menu selection is achieved by briefly pressing the <Menu> button. If this button is pressed for more than 5 seconds programming is initiated. *) If no selection has been made within one minute the basic status of the unit is restored; selections not confirmed by <Enter> will be discarded.

The following menus can be cyclically selected via the <Menu> button:

- Fault information
- Plant information
- Block plant On/Off
- End of information

To select one of the above menus press <Enter>.

Attention!

In the menu „Block plant ON“ this command is carried out at once when pressing <Enter>. If it is not intended to deactivate the plant completely, continue in the programming sequence by pressing <Menu>.

In case you have blocked the plant, press the <Menu> button to select item „Block plant OFF“. Now press the <Enter> button to switch the system on again.

The submenu items in the left column are selected by pressing the <Enter> button. Indications here are more or less self-explanatory.

- No. test cycl. = X
Indicates the number of function tests previously carried out.
- BT time > X min
Indicates the charging condition of the battery after the last battery test.
- FT in x D y H
Indicates the days and hours to the next automatic function test.
- BT in x Days
Indicates the days to the next automatic battery duration test.

*) Settings can only be changed in programming mode. This must exclusively be done by authorized expert personnel having special knowledge of the statutory and technical necessities applicable to the erection and operation of lighting installations!

11 Programming of CeaGuard 48

A programming of CeaGuard 48 must be carried out if

- circuits of the emergency lighting system are to be switched to non-permanent, permanent, or switched permanent lighting mode,
- less than 4 circuits of the emergency lighting are connected to CeaGuard 48,
- less than 12 luminaires are installed in a circuit for emergency lighting purposes,
- the assignment of general lighting and emergency lighting circuits has to be made or modified.

The following is to be observed during programming:

- The programming mode is activated by pressing the „Menu“ button for at least 5 seconds. *)
- If no selection has been made within one minute the programming mode is aborted automatically. Selections not confirmed by <Enter> will be discarded.
- Button designation:
Basic indication on the LC display:
1: Button „Menu“
2: Button „forward“
3: Button „back“
4: Button „Enter“

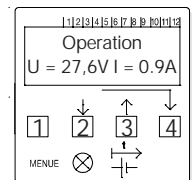

In the descriptive text buttons to be pressed are shown in parentheses, eg <Menu>.

Warning!

During programming the emergency lighting functions of CeaGuard 48 is deactivated. Therefore, take the necessary precautions to safeguard a possible failure of the general lighting circuits.

11.1 Changing Operating Modes Non-Permanent/Permanent Light

In the following example the operating mode „Permanent light ON“ is programmed for Circuit 1 of the emergency lighting system. Other available operating modes are (see product description) „switched permanent light“ and „non-permanent light“.

Basic display:

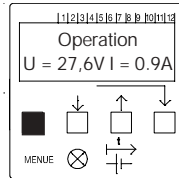

<Menu> Press for 5 seconds

Display 1):

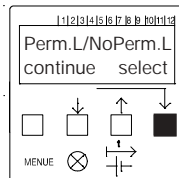

To continue press <Enter> ²⁾

Press <forward> button to cyclically select between

- Circuit 1
- Circuit 2
- Circuit 3
- Circuit 4
- Circuit End

To confirm selection press <Enter>

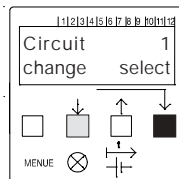

Display 3):

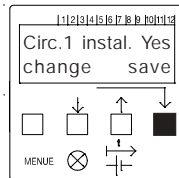

To continue press <Enter> ⁴⁾

Press <forward> button to cyclically select between ¹⁾

- NPL Yes = Non-permanent light
- NPL No = next menu item PL

To confirm selection press <Enter>

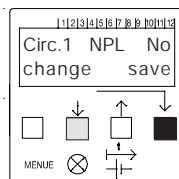

Press <forward> button to cyclically select between ¹⁾

- PL Yes = Permanent light (ON)
- PL No = Switched permanent light (SPL)

To confirm selection press <Enter>

Return to basic display

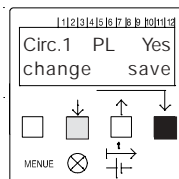

11.2 Delete an Emergency Lighting Circuit (Switch off the Circuit)

In the following example Circuit 3 of the emergency lighting system is deleted (switched off).

Basic display:

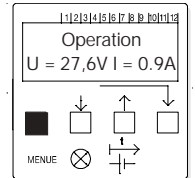

<Menu> Press for 5 seconds

Display 1):

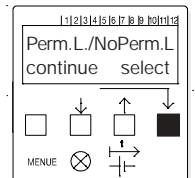

To continue press <Enter> ²⁾

Press <forward> button to cyclically select between

- Circuit 1
- Circuit 2
- Circuit 3
- Circuit 4
- Circuit End

To confirm selection press <Enter>

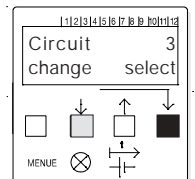

Press <forward> button to cyclically select between

- Circ.3 instal. Yes
- Circ.3 instal. No

To confirm selection press <Enter> ⁴⁾

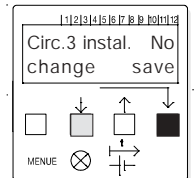

Basic display:

In case of „Circ.3 instal. No“ Circuit 3 of the emergency lighting is cut off.

In case of „Circ.3 instal. Yes“ Circuit 3 with settings for NPL/PL ¹⁾ is switched on.

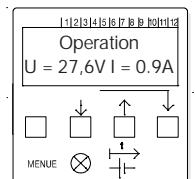

¹⁾ NPL = Non-permanent Light (NoPerm.L)

PL = Permanent Light (Perm.L)

SPL = Switched Permanent Light

²⁾ By pressing <forward> further submenus are selected cyclically (eg „Number of luminaires“).

³⁾ Depending on the set operating mode „Circ.x instal Yes/No“.

⁴⁾ In case of „Circ.x instal. No“, press <Enter> to return to the basic display.

If „Circ.x instal. Yes“ the next menu item is „NPL Yes/No“.

Mounting and Operating Manual CeaGuard 48

11.3 Enter Number of Luminaires of an Emergency Lighting Circuit

In the following example the number and address (1 ... 12) of connected luminaires is entered for Circuit 2 of the emergency lighting system.

<Menu> Press for 5 seconds
The adjacent display will appear

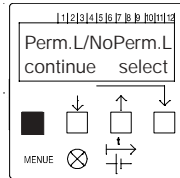

Press <forward> button to cyclically select between

- Perm.L/NoPerm.L
- No. of luminaires
- Device data
- Menu Number
- End programming

To confirm selection press <Enter>

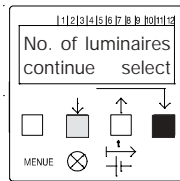

Press <forward> button to cyclically select between

- Circuit 1
- Circuit 2
- Circuit 3
- Circuit 4
- Circuit End 1)

To confirm selection press <Enter>

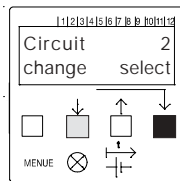

Press <forward> button to cyclically select between

- Circ.2 Luminaires Yes = available
- Circ.2 Luminaires No = not available

To confirm selection press <Enter>

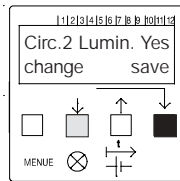

Enter connected luminaire items 1 ... 12 by pressing buttons ²⁾
<forward> = Item not assigned
<back> = Item assigned (X)

To confirm selection press <Enter> for each individual luminaire ³⁾

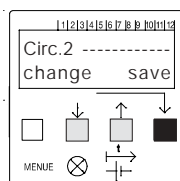

Press the following buttons
<forward> or <back>
<forward>, <Enter>
<forward>, <Enter>
<back>, <Enter>
<forward>, <Enter>
to assign one luminaire to Item 3 and no luminaire to Item 4

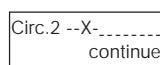
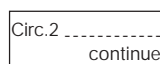

11.4 Query Device Data (Settings of CeaGuard 48)

The procedure outlined here is not meant to change settings. Changes can only be made by programming the relevant function menus. This however is to be left to authorized skilled personnel.

<Menu> Press for 5 seconds
The adjacent display will appear

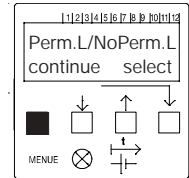

Press <forward> button to cyclically select between

- Perm.L/NoPerm.L
- No. of luminaires
- Device data
- Menu number
- End programming

To confirm selection press <Enter>

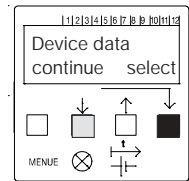

Serial display of the device data:

- Serial No. 000000
- Commissioning 00-00-00
- Version Z00.X

To continue press <Enter>

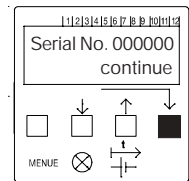

When all the displays have been shown the basic display is automatically restored.

Note: Even when a fault indication is displayed the unit can be switched to programming mode by pressing the <Menu> button so that faults can be eliminated and the basic status restored.

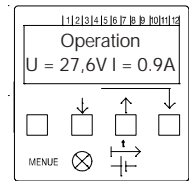

- 1) Pressing the <Enter> button brings you at once back to basic display.
- 2) If „Circ.2 Lum. No“ has been selected, basic display appears at once. The previously set luminaire assignment is deleted.
- 3) If <Enter> is pressed at once when this indication is shown, the basic display is restored and the indicated luminaire assignment remains unchanged.

Mounting and Operating Manual CeaGuard 48

11.5 Programming of Function Menus

The procedure outlined here serves to modify settings of CeaGuard 48.

However, this work must only be carried out by authorized skilled personnel!

<Menu> Press for
5 seconds
The adjacent display will appear.

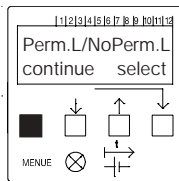

Press <forward> button to
cyclically select between

- Perm.L/NoPerm.L
- No. of luminaires
- Device data
- Menu number
- End programming

To confirm selection press <Enter>

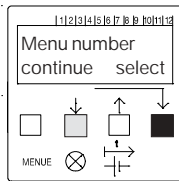

Start selection by pressing
<forward>.
Select Menu No.
via <forward> / <back>

- Select 1st position
(decimal place)
- <Enter>
- Select 2nd position
(unit's place)
- <Enter>

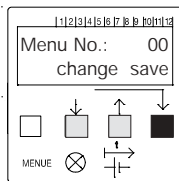

The selection of Menu 05 will
for example result in the display:

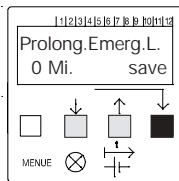

To confirm selection press
<Enter>. The adjacent basic
display will be shown (or a failure
message) without changes having
been effected.

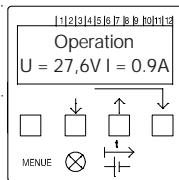

The following menus can be selected and processed:

- Menu 00 Plant type
- Menu 05 Prolonged emergency lighting
- Menu 10 Manual reset
- Menu 15 Buzzer
- Menu 20 Circuit
- Menu 25 CGP connection
- Menu 87 Language
- Menu 99 Serial number

- Menu 00 Plant type

Select plant type featuring 1 hour or 3 hours of emergency lighting operation:



Press <forward> to select between 1h/3h.
Press <Enter> to end selection.

- Menu 05 Prolonged emergency lighting

Select a prolonged operating time for the emergency lighting system (between 0 and 180 minutes for all the circuits):

The emergency lighting remains switched on throughout the prolonged period selected.



Press <forward> / <back> to move in steps of one minute between 0 ... 180 minutes.
Press <Enter> to end selection.

- Menu 10 Manual reset

With respect to plant type select whether manual reset is required:



Press <forward> to select between Yes/No
Press <Enter> to end selection.

Mounting and Operating Manual CeaGuard 48

□ Menu 15 Buzzer

This menu serves to decide whether and when an audible signal is given:

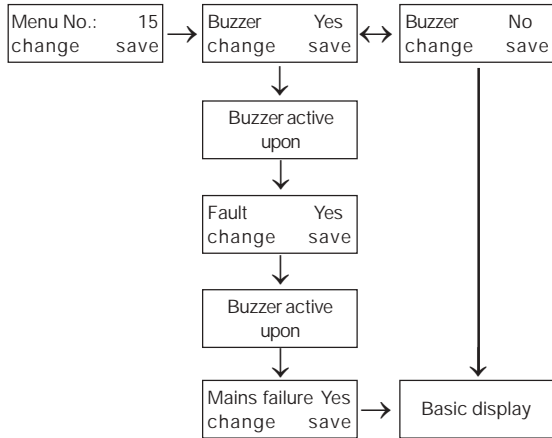

Press <forward> to select between Yes/No.
Press <Enter> to end selection.

All 4 possible Yes/No combinations can be entered for faults or mains failures.

□ Menu 20 Circuit

This menu serves to assign one or two switching inputs for a selected circuit Circ.1 ... Circ.4.

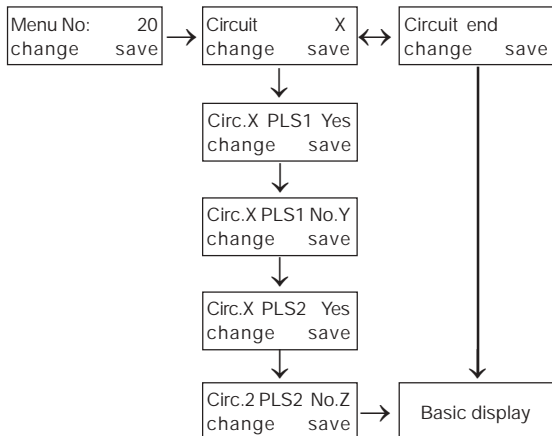

Press <forward> to select between Yes/No.
Press <Enter> to end selection.

Note: PLS = Permanent light switch checking

□ Menu 25 CGP Connection

This menu serves to enter the test cycles or define a connection of CeaGuard 48 to a controller:

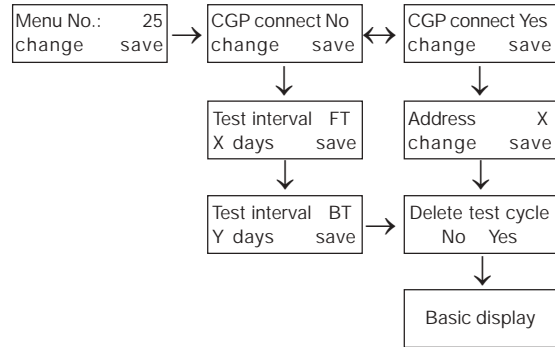

Press <forward> to select between Yes/No
Press <Enter> to end selection.

If „CGP connect“ is negated, the settings for the test cycles of „Function test“ (FT) and „Battery test“ (BT) are made. Press buttons <forward> or <back> to set a test interval ranging between 0 ... 365 days and finalized by pressing <Enter>.

Finally, it is determined whether the current test cycle is to be deleted:

<forward> = No

<back> = Yes

After this selection has been made, the instruction „Delete test cycle No/Yes“ is carried out and the basic status restored.

If 'CGP connect' is affirmed, an address (1 ... 32) is to be selected for CeaGuard 48 under which the unit is contacted by the controller (press <forward> to select between addresses 1 ... 32 cyclically).

Settings for the test cycles „Function test“ (FT) and „Battery test“ (BT) are made via the controller (in this context see the manufacturer's documentation for the controller used, eg CEAG controller CG 48 or CEWA GUARD CGP).

When the address has been assigned it is determined whether the current test cycles of the function test FT and battery test BT shall be deleted:

<forward> = No

<back> = Yes

After this selection has been made, the instruction „Delete test cycle No/Yes“ is carried out and the basic status restored.

Mounting and Operating Manual

CeaGuard 48

☐ Menu 87 Language

This menu serves to select between the languages German/English for the LC display text:

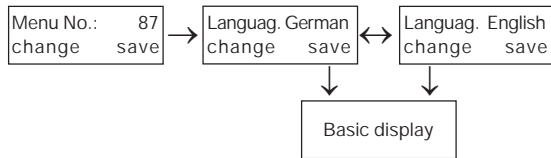

Press <forward> to select the desired language.
Press <Enter> to confirm the selected language to be shown on the LC display.

☐ Menu 99 Serial Number

This menu serves to enter serial number and date of commissioning (or last change of settings). (Press <forward>) to initiate selections or make entries:

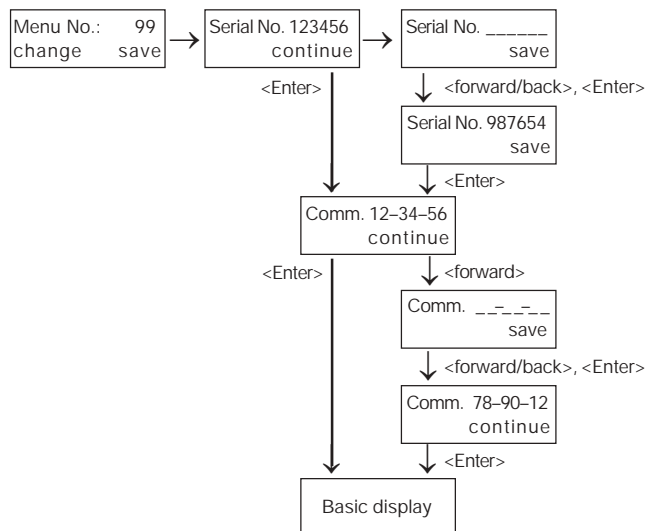

Press <Enter> to confirm and accept entries and selections.
Press <forward> to change over to the input/change mode.

For each selection item the desired individual digit has to be entered by pressing the <forward> or <back> buttons and accepted by <Enter>.

When the last selection/entry has been made the basic display is restored.

12 Troubleshooting and Remedial Action

CeaGuard 48 has test procedures to be manually or automatically performed:

- ☐ Performing function and battery testing manually has been described in Chapter „10 Operation“.
- ☐ Automatic function tests and battery capacity tests are carried out at intervals determined when programming CeaGuard 48 (see Menu 25 under „11.5 Programming of Function Menus“).
- ☐ CeaGuard 48 also monitors the proper functioning of the lighting system and battery charging characteristics during operation.

As a result of the above function tests a fault or malfunction message may be shown on the LC display (or via other indicating elements or controllers installed on central control stations). The response to such fault/malfunction messages is described in this chapter in detail.

Attention!

Only take measures or perform work for which you have been authorized, trained, and qualified. In case faults are experienced in the lighting system that are not mentioned in this chapter,

- ☐ take the required action to make sure all relevant areas are adequately lighted
- or
- ☐ close all endangered areas to rule out they are used
- and
- ☐ get in contact with CEAG without delay.
- ☐ Switch off the plant via menu selection „Block Plant ON“. (see „10 Operation“)

Mounting and Operating Manual

CeaGuard 48

If CeaGuard 48 indicates a fault message the following procedure is recommended:

- ❑ If one of the following fault indications are displayed please take action as explained in this chapter.
 - Fault
 - Collective fault
 - Mains failure
 - Plant blocked
 - No emergency light function
 - Flat battery
 - Manual reset

If „Fault“ is indicated proceed as outlined under Case1 or Case 2 to find out the reason of the trouble.

- ❑ Press the <Menu> button to proceed to the indicating mode and then inform yourself of the fault displayed (how to proceed during normal operation has been comprehensively described in Chapter „10 Operation“).

If the cause of the failure has been determined remedial action must be taken.

- ❑ In the event of technical defects of the general lighting system take appropriate safety measures and remedial action.
- ❑ If CeaGuard 48 has been incorrectly programmed (eg if a non-existing circuit Circ.x is reported as existing and activated or if the luminaire assignment of a given circuit is incorrect) modify programming as necessary (see „12 Programming of CeaGuard 48“).
- ❑ As regards faults indicated on the LC display of CeaGuard 48 proceed as outlined in this chapter.

Case 1: Fault has occurred in an emergency lighting system circuit:

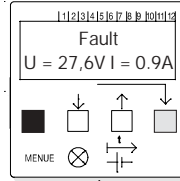

Fault info
Select

Battery Ok
continue

Emerg. L. fault
continue

Circ.1
continue

Circ.2 --*-----
continue

Procedure for fault determination in Case 1:

The LC display of CeaGuard 48 indicates „Fault“ and gives current values of battery voltage and current.

Pressing briefly the <Menu> button, proceed to the indicating mode: „Fault info“

Press <Enter> to go to the first display. If the display shows „Battery Ok“ the fault will be found in the power circuits of the lighting system. Press the <Enter> button again to cause CeaGuard 48 to proceed to the „Emerg. light fault“ indication.

Press <Enter> again to inform yourself of the status of circuits Circ.1 Circ.4 of the emergency lighting system. The „*“ symbol indicates that luminaire 3 in circuit Circ.2 is defect.

Case 2: Fault has occurred in a battery circuit:

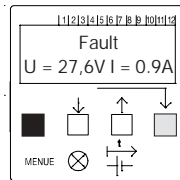

Fault info
Select

Batt. interrupt.
continue

U batt. > max.
continue

U batt. < min.
continue

BT < BT min
continue

Procedure for fault determination in Case 2:

The LC display of CeaGuard 48 indicates „Fault“ and gives current values of battery voltage and current.

Pressing briefly the <Menu> button, proceed to the indicating mode: „Fault info“

Press <Enter> to go to the first display. If faults have occurred in the battery circuit one of the messages shown to the left will be displayed.

Case 3: One of the remaining fault messages is displayed:

- Collective fault
- Mains failure
- Plant blocked
- No emergency light function
- Flat battery
- Manual reset

Procedure for fault determination in Case 3:

There is no need to call up further submenus. Select one of the respective fault indications by briefly pressing the <Menu> button.

Mounting and Operating Manual

CeaGuard 48

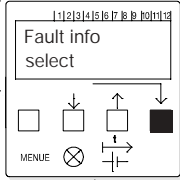
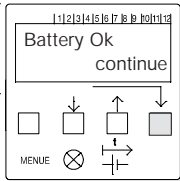
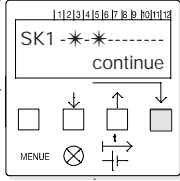
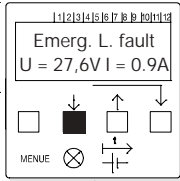
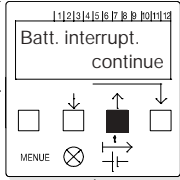
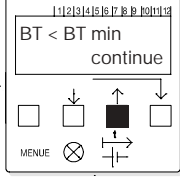
| Fault Characteristic/Display | Cause of Fault | Remedial Action |
|-------------------------------------------------------------------------------------|--------------------------------------|--------------------------------------------------------------------------------------------------------------------------------------------------------------------------------|
| Emergency light fault | | |
|  | One or several luminaires are defect | Briefly press <Menu> button |
|  | Indication can be skipped | Briefly press <Enter> to confirm |
|  | Indication of defect luminaires | The defect luminaires are identified by a "*" The functioning luminaires are identified by a "-" |
|  | | By pressing the <Enter> button repeatedly the remaining power circuits are checked When the fault has been remedied, press the <Test> button to perform a function test |
| Charging trouble: Battery circuit interruption | | |
|  | Battery connection interrupted | Eliminate contact interruption |
| | Charging fuse 2.5 AT is defect | Replace the charging fuse |
| | | Initiate a battery duration test by pressing the <Duration TEST> button |
| Charging trouble: Battery capacity test failed | | |
|  | One or both batteries are defect | Replace both batteries |
| | The batteries were not fully charged | Charge batteries for 20 h and press the <Test> button |
| | Batteries defect | Replace batteries |
| | | Initiate a battery duration test by pressing the <Duration TEST> button |

Mounting and Operating Manual CeaGuard 48

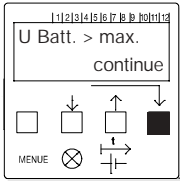
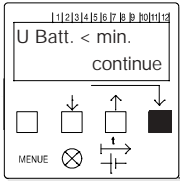
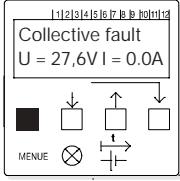
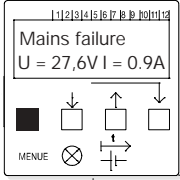
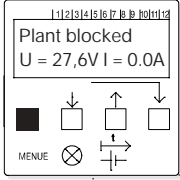
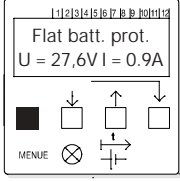
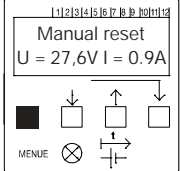
| Fault Characteristic/Display | Cause of Fault | Remedial Action |
|---------------------------------------------------------------------------------------------------------------------------|-------------------------------------------------------------------------------------------------------------------------------------|------------------------------------------------------------------------------------------------------------------------------------------------------------------------------------------------------------------------|
| Excessive battery voltage  | Charger or battery defect | Press <Enter> to acknowledge message Send unit in for repair or call Aftersales Services |
| Battery voltage below min.  | Charger or battery defect | Press <Enter> to acknowledge message Send unit in for repair or call Aftersales Services |
| Collective fault  | Charging and/or emergency light fault | Get precise information about the fault via the control section |
| Mains failure  | 24V loop on terminals S3/S4 is interrupted (3-phase monitoring) No 230V supply voltage can be detected on terminals L, N, PE | Check subdistributors of the general lighting supply system Eliminate mains failure Eliminate mains failure |
| No emergency light function  | 24V loop on terminals S1/S2 of CeaGuard 48 is interrupted The function „Block plant ON“ has been programmed | Switch on the emergency lighting function via remote switch (eg in case of the CEAG F3 remote indicating unit) Programm plant so as to be operative Eliminate faults Press <Enter> to acknowledge message |
| Flat battery protection  | The battery was discharged to the flat battery protection limit | Eliminate mains failure and acknowledge/cancel flat battery message |
| Manual reset  | The function „Manual reset“ has been programmed | Press <Menu> to acknowledge message |

Mounting and Operating Manual CeaGuard 48



CEAG Notlichtsysteme GmbH

Senator-Schwartz-Ring 26
D-59494 Soest/Germany
Phone + 49 (0) 29 21/69-870
Fax + 49 (0) 29 21/69-617
Internet: <http://www.ceag.de>
E-Mail: Info-n@ceag.de

400 71 343 281(C)/ X /02.04/ WES
Technical details subject to alteration!
Instruction valid from October 1999