

Safety Luminaire

Atlantic LED CG-S / Outdoor Wall CG-S



CG-S

- LED safety luminaire with high protection class (IP65) for indoor and outdoor use
- Robust construction from aluminium diecast and high impact resistant cover made of polycarbonate
- Numerous knock-outs for cable entries and double terminal for through-wiring (outdoor wall only one cable entry)
- High spacing by double optics technology and highly efficient HighPower LEDs
- Up to 29 m from luminaire to luminaire with optics for escape route illumination
- Up to 13 m from luminaire to luminaire with optics for wide area illumination
- Minimum service requirement due to high service life of the LEDs (50,000 hours)
- Shortened inspection effort due to CEWA GUARD technology
- Automatic function monitoring of up to 20 luminaires per circuit
- Reduced installation expenditures by STAR technology
- Freely programmable mixed operation of the switching modes per luminaire in one circuit



Atlantic LED R CG-S



Atlantic LED O CG-S



Outdoor Wall CG-S

Luminous flux Φ_E/Φ_N at the end of rated operating time	100 %
Housing material	Aluminium diecast, Polycarbonate (850 °C glow wire resistant)
Enclosure colour	Grey
Weight	one-sided 1.2 kg two-sided 1.3 kg
Type of mounting	Wall- and ceiling mounting
Connection terminals	3 x 2.5 mm ²
Connection voltage	220 - 240 V, 50/60 Hz 176 - 275 V DC
Current consumption with battery operating	21.5 mA
Power consumption mains operation (apparent power / effective power)	8.5 VA / 5.0 W
Permissible temperature range	-20 °C up to +40 °C
Light source	HighPower LEDs 2 x 1.5 W

Ordering details

Scope of supply	Order No.
Safety luminaire Atlantic LED R CG-S, with asymmetric optics for escape route illumination, incl. LED supply and CG-S technology (20 addresses)	120-052-026
Safety luminaire Atlantic LED O CG-S, with symmetric optics for anti-panic / open area illumination, incl. LED supply and CG-S technology (20 addresses)	120-052-028
Safety luminaire Outdoor Wall CG-S, with asymmetric optics for escape route illumination, incl. LED supply and CG-S technology (20 addresses)	120-052-524

Dimensions in mm

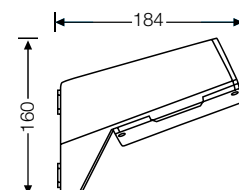
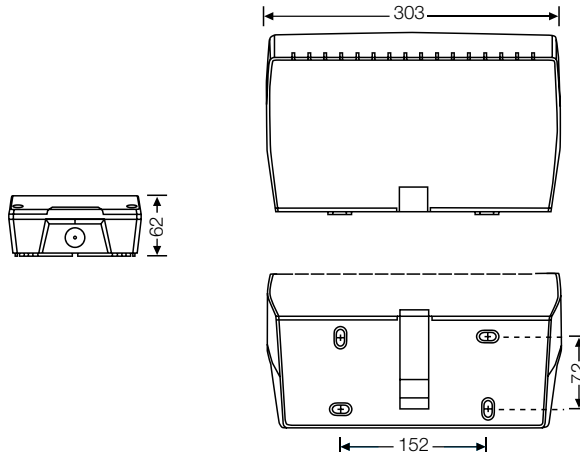
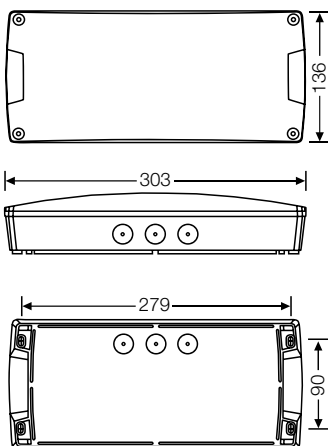

Safety Luminaire

Atlantic LED CG-S / Outdoor Wall CG-S

Engineering help for Atlantic LED R – Asymmetric optics = 1.0 lx (0.5 lx)

Measuring level: 0.02 m, maintenance factor MF = 80 %, battery operation

