



Mounting and Operating instructions

CG Controller CGLine 400

Target group: Skilled electricians



Mounting and Installation Instructions

CG-Controller CGLine 400

Index

1	Safety Notes	4
1.1	Important information about safe operation of an emergency lighting system.....	4
2	Conformity to standards.....	5
3	Technical data	5
3.1	Use as prescribed	6
4	Installation.....	7
4.1	Mounting	7
4.2	Electrical connection	7
5	CG-Controller in the emergency lighting system	8
6	Definition of keys.....	9
7	Status display.....	10
7.1	Fault display.....	10
8	Menu overview.....	11
8.1	Main screen	12
8.1.1	Jump back to the main screen automatically	12
8.1.2	LCD back lighting.....	12
8.2	Main menu	12
8.3	Fault analysis	12
8.4	Status luminaires	13
8.4.1	Status fault display.....	13
8.5	Test menu	14
8.5.1	Start function test for all luminaires	14
8.5.2	Start function test for one line	14
8.5.3	Start duration test for all luminaires	14
8.5.4	Cancel duration test shared	14
8.5.5	Cancel duration test for all luminaires.....	15
8.5.6	Start duration test for one line.....	15
8.5.7	Cancel duration test for one line	15
8.5.8	Duration test even.....	15
8.5.9	Duration test uneven.....	15
8.6	Block / release	16
8.6.1	Block all.....	16
8.6.2	Release all	16
8.6.3	Block one line.....	16
8.6.4	Release one line.....	16
8.7	Setup CG-Controller	17
8.7.1	Select language	17
8.7.2	Time and date	17
8.7.2.1	Changeover to summer time.....	17
8.7.2.2	Changeover to winter time	17
8.7.3	Next function test (FT).....	17
8.7.4	Next duration test (DT).....	18
8.7.4.1	Activate shared DT.....	18
8.7.4.2	Main screen for shared DT = active	18
8.7.4.3	Main screen for DT started at the luminaire.....	19
8.7.4.4	Automatic displacement of the next DT after mains failure.....	19
8.7.5	Relais settings.....	19

Mounting and Installation Instructions

CG-Controller CGLine 400

8.7.5.1 Relais selection battery operation	20
8.7.5.2 Relais selection FT runs.....	20
8.7.5.3 Relais selection DT runs	20
8.7.5.4 Relais selection com. failure luminaire.....	20
8.7.5.5 Relais selection luminaire failure	20
8.7.5.6 Relais selection charging failure	20
8.7.5.7 Relais selection test failure	20
8.7.5.8 Relais selection RELAIS COMPLETELY OFF	21
8.7.5.9 Relais selection STANDARD	21
8.7.6 Serial number	21
8.7.7 Customer service info	21
8.7.8 Password	22
8.7.8.1 Activate password.....	22
8.7.8.2 Deactivate password.....	22
8.7.8.3 Submenu activate password.....	22
8.7.8.4 Menu password request.....	22
8.8 Setup luminaires	23
8.8.1 Automatic search of luminaires	23
8.8.1.1 Submenu automatic search	23
8.8.1.2 Submenu automatic search All lines	23
8.8.2 Add luminaire	24
8.8.3 Remove luminaire	25
8.8.4 Luminaires overview	25
8.8.4.1 Symbol before ID	25
8.8.5 Change luminaire name.....	26
8.8.6 Luminaire versions.....	26
8.8.7 Delete lines	26
8.8.8 Line names	26
8.8.9 Address faults list.....	27
8.8.10 Clear address faults	27
8.9 Memory card.....	27
8.9.1 Display log book.....	27
8.9.2 Display log book of sum entries	28
8.9.3 Delete log book	28
8.9.4 Configuration -> SD	28
8.9.5 Configuration <- SD	28
8.9.6 Configuration made by the PC software	29
9 LED displays	30
9.1 LED displays operation, test and failure	30
9.1.1 Control module software (LED displays).....	30
9.1.1.1 Operation, green LED	30
9.1.1.2 Test, yellow LED	30
9.1.1.3 Failure, red LED	30
10 Memory card	31
10.1 SD files.....	31
11 I/O-module for connection of an F3-remote indication	32

Mounting and Installation Instructions

CG-Controller CGLine 400

1 Safety notes

- In accordance with specifications, the CG-Controller must be operated in an undamaged and fault-free state!
- When performing tasks on the emergency lighting system, make certain that the system is disconnected from electrical power!
Note the various power supplies for normal and emergency mode in this regard.
- Before placing the device in service, the emergency lighting system must be tested according to the instructions listed in the „installation“ section of the operating instructions!
- Please note for all tasks on the device applicable national safety and accident prevention requirements and the following safety instructions in the operating instructions that are identified by a !
- You must comply with the national statutes and directives governing
 - the construction and control of a system for main and emergency lighting.
 - inspection and safety tests (e. g. for function and duration tests.)

1.1 Important information about safe operation of an emergency lighting system

WARNING!

This system is part of the emergency and main lighting system and therefore part of the safety equipment of a building or company. Unauthorised and unskilled work on the equipment can lead to the failure of the main and/or emergency lighting system and hence to

- significant hazards to persons,
- significant damage to plant and machinery,
- faults and interruptions in the production process.

Once the system has been assembled, connected up and commissioned, the following additional operations must be carried out for normal operation:

- monitoring and maintaining a record of system functions
- safety measures during faults and shutdowns
- carrying out the safety inspections as required by statutes and directives

The operator of the emergency lighting system is responsible for organising and supervising this work. The following information must be specified in writing and made available at all times:

- The nature and extent of the work
- Documentation of work results
- Responsibilities and permits for carrying out the work
 - Which persons may carry out which operation?
 - Which persons are responsible for supervising the work?
- Duties of reporting (e. g. in case of faults or function tests)
- Organisational measures when working on the emergency lighting system.

This may include:

- Duties of information and reporting on the start, duration and end of the work
- Safety measures while the work is being carried out:
e. g. standby lighting, power supply isolation and lock-out (e. g. removing the fuses, key-operated switch, safety signage)

Mounting and Installation Instructions

CG-Controller CGLine 400

- Safety equipment for the personnel carrying out the work on the plant (e. g. suitable work clothing and personal protection equipment)
- Safety equipment providing protection from hazards caused by adjacent plant.

In particular, inspections and safety checks and their documentation must be carried out by specially authorised engineering personnel (in accordance with the national statutes and directives).

NOTE!

For modifications to the emergency lighting system and the programming and for safety inspections, please contact your local CEAG office or experts of authorised organisations.

2 Conformity to standards

In conformity with: DIN EN 50172, DIN VDE 0100-718 und E DIN VDE 0108-100!

ATTENTION!

CEAG Notlichtsysteme GmbH cannot accept no liability and/or give no warranty in respect of any defects that may occur with the supply and installation of CEAG emergency lighting systems and luminaires on the basis of other standards and regulations which are mandatory in complete installation packages in conjunction with CEAG products.

3 Technical Data

Power supply voltage:	230 V AC \pm 10 % or 24 V DC
Power consumption (230 V):	max. 80 mA
(24 V):	max. 450 mA
Alarm contact:	1 x UM, 24 V 0,5 A; free programmable
Display pad:	Lighted display, alphanumeric 4 x 20 characters
Insulation class:	II
Class of protection acc. to EN 60527:	IP 65
Ambient temperature:	-5 °C ... + 40 °C
rel. humidity:	0 - 95 %, non condensing
Connection terminals:	max. 2,5 mm ²
Weight:	ca. 1,8 kg
Dimensions (L x B x T)/mm:	184 x 240 x 112

Data CGLine bus

Power supply voltage bus:	22,5 V DC
Max. perm. voltage drop:	13 V
Bus current:	400 mA

Mounting and Installation Instructions

CG-Controller CGLine 400

3.1 Use as prescribed

The CG-Controller is designed for monitoring and controlling CEAG CGLine self contained luminaires. Up to 400 CGLine luminaires can be operated in the same simple manner on one controller. Their operation is program controlled. They must be programmed and set up by engineers with specialist knowledge of the legal and technical requirements governing the assembly and operation of lighting systems.

The system is built to the latest state of the art and according to the recognised codes of practice in safety engineering.

The number of electronic devices in use in recent years has increased sharply, as of course has radio interference, for every electronic device, machine or system emits different types of radiation. Interference can occur especially in today's highly automated industries. It can lead to malfunctions and even to the failure of entire plants. The overlaying of different types of interference increases the overall level of radiated noise, hence the need to protect all devices from electromagnetic interference (EMI). In industrial process engineering in particular, a high level of immunity is required for electrical instrumentation and control (I&C) equipment. This is why all electronic devices are subject to mandatory CE marking.

CEAG products comply with the requirements of EC Directives 89/336/EEC (EMC directive) and 73/23/EEC as amended by Directive 93/68/EEC (low voltage directive) and are entitled to carry the CE marking.

If luminaires with electronic ballast comply with the EMC directives, then the interference produced by the high frequency operation of the electronic ballast is within the legal limits. Nevertheless, electronic devices may cause interference in individual cases.

Only operate the system and parts connected to it when they are in a technically perfect condition.

The applicable work and safety regulations are set out in these assembly and operating instructions and the general and specialist technical guidelines and accident prevention regulations.

CEAG can give no warranty or accept any liability for damage or consequential damage caused as a result of

- improper use,
- failure to comply with regulations and codes of conduct for the safe operation of the system,
- unauthorised or inexpert modifications
 - to the connections and settings of the system,
 - or for programming the system,
- operating proscribed or unsuitable devices or groups of devices.

Mounting and Installation Instructions

CG-Controller CGLine 400

4. Installation

You must observe the applicable safety requirements for setting up and operating electrical equipment as well as the Device Safety Law and all generally recognised codes of practice!

4.1 Mounting

Apply bore holes as shown in the figure. Fasten the device in place with suitable screws. Tighten the screws only to finger tightness. Or fix device on DIN rail! (dimensions in mm)

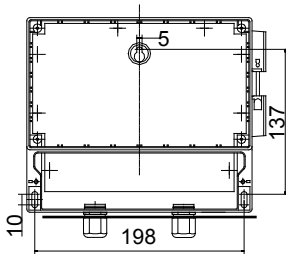

4.2 Electrical Connection

Mains connection

The device is designed for operation at 230 V AC or 24 V DC. Lines must be connected as shown below.

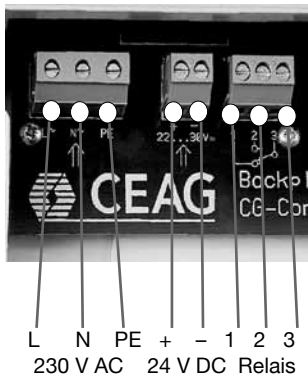

Potential free contact

The controller provides a freely programmable circuit contact (1 - 2 - 3, figure above). Energising of the relay can be assigned to various events. See the «Relais settings» menu.

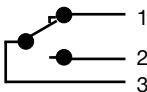

Mounting and Installation Instructions

CG-Controller CGLine 400

Bus cables

The 2-core bus line from the connected CEAG CGLine self contained luminaires must be connected to terminals D1, D2, D3 and D4.

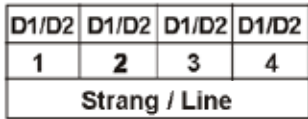
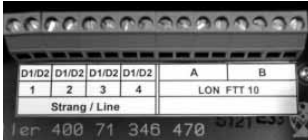

2-core bus connection to line 4

5 CG-Controller in the emergency lighting system

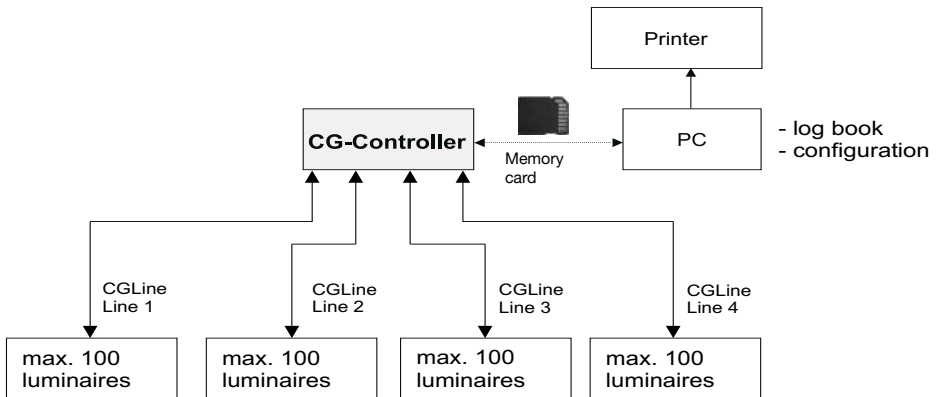

Cable laying CGLine bus

2-core bus cable, unshielded. Free bus-topology.

Length of cable per line

Cross section	length	line in sum
0.5 qmm	450 m	1.800 m
1.0 qmm	900 m	3.600 m
1.5 qmm	1.350 m	5.400 m

Data per line

Supply voltage bus	22,5 V DC
Max. allowed voltage drop	13 V
Bus current	400 mA

Mounting and Installation Instructions

CG-Controller CGLine 400

6 Definition of keys

Definition of keys

Key	Main meaning
Menu	<input type="checkbox"/> If main screen, switch to the main menu selection <input type="checkbox"/> Switch to the menu one level higher
ENTER	<input type="checkbox"/> Confirm <input type="checkbox"/> Open menu item <input type="checkbox"/> Exit input and accept the changes
↵	<input type="checkbox"/> Select the menu item above <input type="checkbox"/> Raise value
↑	<input type="checkbox"/> Select the menu item below <input type="checkbox"/> Reduce value
⇩	<input type="checkbox"/> Back <input type="checkbox"/> Previous cursor position, previous input field <input type="checkbox"/> Reduce value <input type="checkbox"/> Deactivate
⇨	<input type="checkbox"/> Forward <input type="checkbox"/> Next cursor position, next input field <input type="checkbox"/> Raise value <input type="checkbox"/> Activate

Control panel

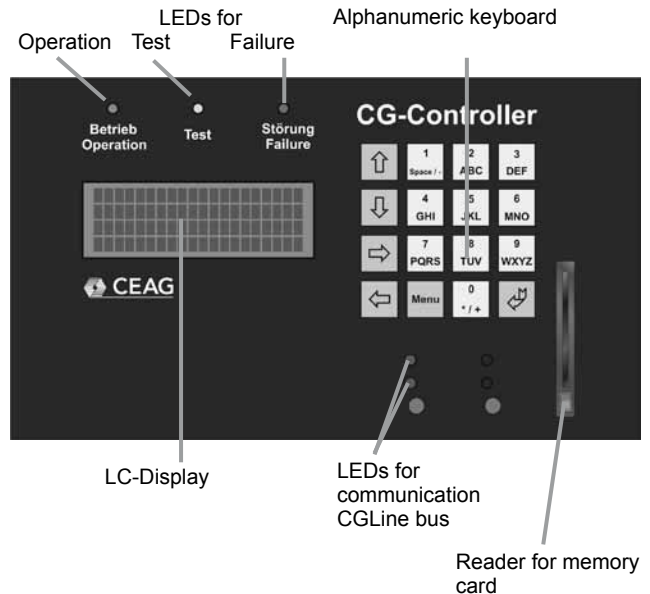

Mounting and Installation Instructions

CG-Controller CGLine 400

7 Status display

Priority	Line 2 (main screen)
high ↑	1 DT runs
	2 FT runs
	3 Line 1 blocked
	Lines 1/2 blocked
	Lines 1/2/3 blocked
	Lines 1/2/3/4 blocked
	4 Shared DT active
↓ low	5 Battery operation (mains failure)
	6 Operation

If a status with a lower priority is being displayed and a status with a higher priority occurs, the newer status with the higher priority will be displayed. If this new higher status drops out again, the old, lower status will be displayed.

As soon as no more status messages are pending, „operation“ is displayed. In the „Status luminaire“ menu line 2 the status of a previously selected device of same priority is displayed.

7.1 Fault display

Priority	Line 3 (main screen)
high ↑	1 No interface card
	2 Communication failure
	3 Luminaire failure
	4 Charging failure
	5 Test failure ⁵
	6 Test failure ⁶
	7 Address failure
↓ low	8 Failure CG-Controller
	9 blank line = no failure (when shared DT runs = balance time display)

⁵ The test failure prio 5 gets created at the end of an FT, when the luminaire, due to low battery capacity, could not run the FT.

⁶ The test failure prio 6 gets created at the end of an DT, when the luminaires fail. The batteries of the corresponding luminaires should be replaced.

In the „Status luminaire“ menu line 3 the fault of a previously selected device of same priority is displayed. According to standards the failure with the highest priority is displayed.

Mounting and Installation Instructions

CG-Controller CGLine 400

8 Menu overview

Main menu	1. Submenu	2. Submenu
Luminaire Failure	Select line & luminaire	
Status Luminaire	Select line & luminaire	
Test Menu	Start FT all luminaires Start FT line _____	Select line
	Start DT all luminaires Cancel shared DT ⁷⁾ Cancel DT Start DT line _____	Select line
	Cancel DT line DT even DT uneven	
Block, release ²⁾	Block all ²⁾ Release all ²⁾ Block line ²⁾ _____	Select line
	Release line ²⁾ _____ Status ²⁾	Select line
Setup CG-Controller ²⁾	Select language ²⁾ Time and Date ²⁾ Next FT ²⁾ Next DT ²⁾ Relais settings ²⁾ Serial number ²⁾ Customer Service info ²⁾ Password ²⁾	
Setup Luminaires ²⁾	Aut. search of luminaire ²⁾ Add luminaire ²⁾ Remove luminaire ²⁾ Luminaires overview ²⁾ Change luminaire name ²⁾ Luminaire versions ²⁾ Delete line ²⁾ Line names ²⁾ Address faults list ²⁾ Remove address faults ²⁾	All lines or line Select line & luminaire Select line & luminaire
Memory Card	Display log book ²⁾ Delete log book ²⁾ Configuration→SD ²⁾ Configuration← SD ²⁾	
CG-Controller Failure ¹⁰⁾	CG-Controller failure Listing	

²⁾ Menu item is password-protected.

⁷⁾ only shown during a shared DT runs.

¹⁰⁾ only shown due to present failure

⬇ Cursor position lower

⬆ Cursor position higher

☑ Select menu item

Menu One menu level higher

Mounting and Installation Instructions

CG-Controller CGLine 400

8.1 Main screen

Line	LC-Display:
1	Controller CGLine 400
2	Status display
3	Fault display
4	13:29:17 24.05.2007

Operation: With the key **Menu** a change into the main menu occurs.

- Line 1 = Type of CG-Controller
Line 2 = Status display (default = operation = no status)
Line 3 = Fault display (default = blank line = no failure)
can show a bargraph or the luminaire which is even tested
Line 4 = Actual time and date

8.1.1 Jump back to the main screen automatically

If no key is activated in a submenu for about 3 minutes, the system automatically switches to the main screen.

8.1.2 LCD back lighting

When a key is pressed, the display is lit up for about 3 minutes.

8.2 Main menu

Line Selection (Main menu)	
1	Failure luminaires ■
2	Status luminaires
3	Test menu
4	Block, release ↓
5	Setup CG-Controller
6	Setup luminaires

etc.

Menu Back to the main screen

■ = current cursor position

Operation:

Menu Change to main screen

↑ higher

↓ lower

↕ selects menu item

8.3 Fault analysis

All existing failures get displayed. If no failure exists the menu cannot be seen, means is blank.

Line	Selection (Main menu)
1	Luminaire failure ■
2	Status luminaires
3	Test menu
4	Block, release ↓
5	Setup CG-Controller
6	Setup luminaires
7	Memory card

Line	Display:
1	Str. 1 Adr. 003 7FFFDE
2	„Name of luminaire“
3	Charging failure
4	Change arrows

Operation:

Menu One menu higher

↓ previous failure

↑ next failure

↕ perhaps details are shown regarding to the selected failure

Mounting and Installation Instructions

CG-Controller CGLine 400

8.5 Test Menu

Line Selection (Main menu)

1	Luminaire failure
2	Status luminaires
3	Test menu <input type="checkbox"/>
4	Block, Release <input type="button" value="↓"/>
5	Setup CG-Controller
6	Setup luminaires
7	Memory card

Line Display:

1	Start FT all luminaires
2	Start FT line
3	Start DT all luminaires
4	Cancel shared DT
5	Cancel DT all
6	Start DT line
7	Cancel DT line
8	DT line even
9	DT line uneven

Operation:

- [Menu] One menu higher
- ↓ Cursor position lower
- ↑ Cursor position higher
- ☑ Select menu item

Note: Line 4:

„cancel shared DT“ is only displayed when a shared DT runs.

8.5.1 Start function test for all luminaires

Line Selection (Submenu)

1	Start FT all luminaires <input type="checkbox"/>
2	Start FT line
3	Start DT all luminaires
4	Cancel shared DT <input type="button" value="↓"/>
5	Cancel DT all
6	Start DT line

Line Display:

1	Start FT all luminaires
2	
3	
4	Start n / y

Operation:

- [Menu] One menu higher
- ⇌ / ⇐ Selection in line
- 4: „No/Yes“
- ☑ Start test

The manual FT gets started. It gets not started during a DT runs. The function test checks operation-readiness of the light sources in battery operation.

8.5.2 Start function test for one line

Line Selection (Submenu)

1	Start FT all luminaires
2	Start FT line <input type="checkbox"/>
3	Start DT all luminaires
4	Cancel shared DT <input type="button" value="↓"/>
5	Cancel DT all
6	Start DT line

Line Display:

1	Start FT line
2	Line: 4
3	
4	Start n / y

Operation:

- [Menu] One menu higher
- ⇌ / ⇐ Selection in line
- 2: select line
- 4: „No/Yes“
- ☑ Start test

8.5.3 Start duration test for all luminaires

Line Selection (Submenu)

1	Start FT all luminaires
2	Start FT line
3	Start DT all luminaires <input type="button" value="↑"/>
4	Cancel shared DT
5	Cancel DT all
6	Start DT line

Line Display:

1	Start DT all luminaires
2	
3	
4	Start n / y

Operation:

- [Menu] One menu higher
- ⇌ / ⇐ Selection in line
- 4: „No/Yes“
- ☑ Start test

The duration test checks whether the battery in the emergency luminaire achieves the specified nominal operation duration (1h/3h). **To achieve optimal battery service life, we recommend carrying out the duration test four times yearly (every three months).**

8.5.4 Cancel shared Duration test

If a shared duration test is active (you can see this by checking the main screen regarding the next DT) you can delete it with this menu item.

Mounting and Installation Instructions CG-Controller CGLine 400

8.5.5 Cancel duration test for all luminaires

Line	Selection (Submenu)	Line	Display:	Operation:
2	Start FT line	1	Cancel DT	[Menu] One menu higher
3	Start DT all luminaires	2		[Left]/[Right] Selection in line
4	Cancel shared DT ↑	3		4: „No/Yes“
5	Cancel DT all	4	Start n / y	[Enter] Confirm selection
6	Start DT line			
7	Cancel DT line			

8.5.6 Start duration test for one line

Line	Selection (Submenu)	Line	Display:	Operation:
2	Start FT line	1	Start DT line	[Menu] One menu higher
3	Start DT all luminaires	2	Line: 4	[Left]/[Right] Selection in line
4	Cancel shared DT ↑	3		2: select line
5	Cancel DT all	4	Start n / y	4: „No/Yes“
6	DT line			[Enter] Start test
7	Cancel DT line			Perh. in line 3: Battery is not charged

8.5.7 Cancel duration test for one line

Line	Selection (Submenu)	Line	Display:	Operation:
2	Start FT line	1	Cancel DT line	[Menu] One menu higher
3	Start DT all luminaires	2	Line: 4	[Left]/[Right] Selection in line
4	Cancel shared DT ↑	3		2: Select line
5	Cancel DT all	4	Start n / y	4: „No/Yes“
6	BT line			[Enter] Confirm selection
7	Cancel DT line			

8.5.8 Duration test even

Starts a duration test for all lines on even addresses.

8.5.9 Duration test uneven

Starts a duration test for all lines on uneven addresses.

Mounting and Installation Instructions

CG-Controller CGLine 400

8.6 Block, release

Line Selection (Main menu)

1	Luminaire failure
2	Status luminaire
3	Test menu
4	Block, release ↓
5	Setup CG-Controller
6	Setup luminaires
7	Memory card

Line Display:

1	Block all
2	Release all
3	Block line
4	Release line

Operation:

- [Menu] One menu higher
- ↵ Select menu item

By means of this remote switch all luminaires or lines can be switched off from afar.

Specialty:

Luminaires are not able to receive orders when a blocked line gets released during no mains exists. The luminaires stay blocked. The controller displays a „communication failure“. When mains returns the controller gets the information that the line is still blocked, abolishes the „communication failure“ and displays „blocked“.

8.6.1 Block all

Line Selection (Submenu)

1	Block all ■
2	Release all
3	Block line
4	Release line

Line Display:

1	Block all
2	
3	
4	Block all n / y

Operation:

- [Menu] One menu higher
- ↵ / ⏪ Selection in line
- 4: „No/Yes“
- ↵ Confirm selection

8.6.2 Release all

Line Selection (Submenu)

1	Block all
2	Release all ■
3	Block line
4	Release line

Line Display:

1	Release all
2	
3	
4	Release all n / y

Operation:

- [Menu] One menu higher
- ↵ / ⏪ Selection in line
- 4: „No/Yes“
- ↵ Confirm selection

8.6.3 Block one line

Line Selection (Submenu)

1	Block all
2	Release all
3	Block line ■
4	Release line

Line Display:

1	Block line
2	Line 4↵
3	
4	Start n / y

Operation:

- [Menu] One menu higher
- ⏴ Cursor position lower
- ⏵ Cursor position higher
- ↵ / ⏪ Selection in line
- 2: Line 1 ... 4
- 4: „No/Yes“
- ↵ Confirm selection

8.6.4 Release line

Line Selection (Submenu)

1	Block all
2	Release all
3	Block line
4	Release line ■

Line Display:

1	Release line
2	Line 4↵
3	
4	Start n / y

Mounting and Installation Instructions CG-Controller CGLine 400

8.7 Setup CG-Controller

Line Selection (Main menu)

1	Luminaire failure
2	Status luminaires ↑
3	Test menu
4	Block, Release
5	Setup CG-Controller ↓
6	Setup luminaire
7	Memory card

Line Display

1	Select language
2	Time and date
3	Next FT
4	Next DT
5	Relais settings
6	Serial number
7	Customer Service info
8	Password

Operation:

- [Menu] One menu higher
- ↓ Cursor position lower
- ↑ Cursor position higher
- ☑ Select menu item

8.7.1 Select language

Line Selection (Submenu)

1	Select language
2	Time and date
3	Next FT
4	Next DT ↓
5	Relais settings
6	Serial number
7	Customer service info

Line Display

1	Sprache : deutsch
2	Language : english
3	
4	

Operation:

- [Menu] Accept language
- ↓ / ↑ Select language
- ☑ Accept language

8.7.2 Time and date

Line Selection (Submenu)

1	Select language
2	Time and date
3	Next FT
4	Next DT ↓
5	Relais settings
6	Serial number
7	Customer service info

Line Display

1	Time and date
2	14:15 13.05.2007
3	↓ ↑ ⇐ ⇨ change
4	☑ = accept

Operation:

- [Menu] Acceptation and one menu higher
- ⇐ / ⇨ right / left
- ↓ / ↑ Reduce/increase value
- ☑ Acceptation and one menu higher

8.7.2.1 Changeover to summer time

Summer time can be changed over in the submenu 'Time and date' by pressing button 7. Time gets risen by 1 hour. Button 7 = PQRS, S = summer time.

8.7.2.2 Changeover to winter time

Winter time can be changed over in the submenu 'Time and date' by pressing button 9. Time gets reduced by 1 hour. Button 9 = WXYZ, W = winter time.

8.7.3 Next function test (FT)

Line Selection (Submenu)

1	Select language
2	Time and date
3	Next FT
4	Next DT ↓
5	Relais settings
6	Serial number
7	Customer service info

Line Display:

1	Next FT
2	14:15 13.05.2007
3	↓ ↑ ⇐ ⇨ change
4	Interval in days: 007

Operation:

- [Menu] Acceptation and one menu higher
- ⇐ / ⇨ right/left
- ↓ / ↑ Reduce/increase value
- ☑ Acceptation and one menu higher

The automatic FT gets programmed. During a DT runs the automatic FT gets not started!

Mounting and Installation Instructions

CG-Controller CGLine 400

8.7.4 Next duration test (DT)

The time of the next automatic start of the battery capacity test gets defined. This test should proceed outside working hours, e. g. 01:00 am, s. IEC60234, chapter 7.2ff 'Automatic test for battery powered emergency escape lighting'.

Line	Selection (Submenu)	Line	Display:	Operation:
1	Select language	1	Next DT	[Menu] Acceptation and one menu higher
2	Time and date	2	14:15 13.05.2007	[←] / [→] right/left
3	Next FT	3	↓ ↑ ⇌ ⇐ change	[↓] / [↑] Reduce/increase value
4	Next DT	4	Interval in months: 011	[↓] Acceptation and one menu higher
5	Relais settings			
6	Serial number			
7	Customer service info			

8.7.4.1 Activate shared DT

Line	Display:	Bedienung:
1	Shared DT?	[Menu] Acceptation and one menu higher
2	24 hours interval	[→] Line 4: yes = activated
3	all/shared	[←] Line 4: no = deactivated
4	n / y	[↓] Acceptation and one menu higher

When selection finishes with n = no = shared DT deactivated, an automatic DT for all luminaires occurs.

If the shared DT is activated only luminaires with a specific type of address (e. g. default = even addresses) start the DT at the programmed time (time = DT = DT-time). 24 hours later a DT on the other type of address occurs automatically (e. g. uneven addresses).

8.7.4.2 Main screen for shared DT = active

Line	Display:	Operation:
1	Controller CGLine 400	[Menu] Menu
2	Shared DT runs	
3	next DT 23:56h	
4	17:02:11 05.11.2007	

Cancel shared DT

While the first half of the shared DT is activated (even addresses) it can be cancelled by „Test menu -> cancel DT“. However, the second half (uneven addresses) follows 24 hours later. If this test should also be cancelled, this can be done by „Test menu ->cancel shared DT“. When the second half is still active (uneven addresses) cancel it by „Test menu -> cancel DT“

Mounting and Installation Instructions

CG-Controller CGLine 400

8.7.4.3 Main screen for DT started at the luminaire

After starting a DT at one luminaire either „DT runs“ or „shared DT runs“ is displayed in the main screen. This depends on how the automatic DT has been programmed, shared or not shared.

or:

Line	Display:
1	Controller CGLine 400
2	DT runs
3	
4	16:34:11 04.03.2007

Line	Display:
1	Controller CGLine 400
2	shared DT runs
3	
4	13:26:17 18.08.2007

8.7.4.4 Automatic displacement of the next DT after mains failure

In battery operation (failure of mains supply) the „Next DT“ is forwarded by 24 hours to 7 days. After recovery of the mains supply the new start of the next DT is calculated. All future DT's refer to this date. This function provides that no duration test is started when in the past 24 hours a luminaire was in battery mode. Therefore, the controller asks every luminaire if they were in battery mode during that time before emitting a DT-instruction. This event leads to a log book entry. If in the next 24 hours a new DT can not be started again this leads to a new log book entry, as well.

8.7.5 Relais settings

The relais is only activated if enough luminaires exist. Not every failure-event is available as an relais-event (address-failure, no interface-card, no memory card (failure of CG-Controller) etc.).

After selection of the menu-item „Relais“ the switch status gets displayed.

Line	Selection (Submenu)
1	Select language
2	Time and date ↑
3	Next FT
4	Next DT
5	Relais settings ↓
6	Serial number
7	Customer service info

Line	Display:
1	-----
2	Switch status
3	ON
4	Continue with ↻

Operation:
 Continue

Line	Display:
1	<input type="checkbox"/> Battery operation
2	<input type="checkbox"/> FT runs
3	<input type="checkbox"/> DT runs
4	<input checked="" type="checkbox"/> Com.fail.luminaire ↓
5	<input checked="" type="checkbox"/> Luminaire failure
6	↳ Charging failure
7	↳ Test failure
8	Relais compl. off
9	STANDARD

Operation:
 [Menu] Acceptation and one menu higher
 [↓] / [↑] Selection of line (lower/higher)
 Relais switches =
 Relais does not switch =

Mounting and Installation Instructions

CG-Controller CGLine 400

8.7.5.1 Relais selection battery operation

The relais switches when one or more luminaires get a mains failure.

8.7.5.2 Relais selection FT runs

The relais switches when one or more luminaires run a function test.

8.7.5.3 Relais selection DT runs

The relais switches when one or more luminaires run a duration test.

8.7.5.4 Relais selection com. luminaire failure

The relais switches when one or more luminaires generate a communication failure at the CG-Controller. This happens when a luminaire, addressed to the CG-Controller, formerly worked but later shows a defect. Same occurs when the CG-S interface respectively the 2-core dataline to the luminaire fails.

8.7.5.5 Relais selection luminaire failure

The lamp or the electronic module of the luminaire is defect.

8.7.5.6 Relais selection charging failure

The battery or the electronic module of the luminaire is defect.

8.7.5.7 Relais selection test failure

1. Test failure prio. 5 (failure of function, charging too low for testing)

At the end of an FT all current luminaire-statusbytes get evaluated. When Bit 1 = 'luminaire failure', a luminaire failure gets entered into the log book. When Bit 4 and 7 are set, 'log book event 0x5D' gets written (FT failure, sum).

2. Test failure prio. 6 (test failure of a luminaire, Bit 4 in statusbyte)

The test failure of a luminaire will be built as follows:

During a DT when its end can not be reached (e. g. 3 hours). At the end of an FT all current luminaire-statusbytes get evaluated. When Bit 4 = test failure deleted, the end of an DT gets entered into the log book. If the Bit is set a DT test failure -> DT compl. not possible 0 x 5C (battery capacity too low, sum) gets entered into the log book.

Battery gets exchanged during the DT. When the yellow LED lights up and the red one blinks it means 'charge failure'. After the new battery is identified, a test failure exists because the DT doesn't reach the end. The luminaire shows a DT failure when the green and the yellow LED light up, the CG-Controller than shows 'test failure'.

This 'test failure' is shown in the total failure display (prio. 5 ,6). If the luminaire has a 'luminaire failure' at the same time this is shown in the total failure display (prio. 3).

The 'test failure' gets cancelled when a new DT is passed, e. g. after exchanging the battery.

Mounting and Installation Instructions CG-Controller CGLine 400

8.7.5.8 Relais selection RELAIS COMPL. OFF

Sets all relais events on: Relais does not switch =

8.7.5.9 Relais selection STANDARD

When one or more of the following status messages occurs the relais switches.

No. Status message	Failure message
1 -	
2	Com. failure luminaire
3	Luminaire failure
4	Charge failure
5	Test failure

8.7.6 Serial number

<table border="1" style="width: 100%; border-collapse: collapse;"> <thead> <tr> <th style="text-align: left;">Line</th> <th style="text-align: left;">Selection (Submenu)</th> </tr> </thead> <tbody> <tr><td>1</td><td>Select language</td></tr> <tr><td>2</td><td>Time and date</td></tr> <tr><td>3</td><td>Next FT ↑</td></tr> <tr><td>4</td><td>Next DT</td></tr> <tr><td>5</td><td>Relais settings</td></tr> <tr><td>6</td><td>Serial number ↓</td></tr> <tr><td>7</td><td>Customer service info</td></tr> </tbody> </table>	Line	Selection (Submenu)	1	Select language	2	Time and date	3	Next FT ↑	4	Next DT	5	Relais settings	6	Serial number ↓	7	Customer service info	<table border="1" style="width: 100%; border-collapse: collapse;"> <thead> <tr> <th style="text-align: left;">Line</th> <th style="text-align: left;">Selection:</th> </tr> </thead> <tbody> <tr><td>1</td><td>Serial-No: 123456/78</td></tr> <tr><td>2</td><td></td></tr> <tr><td>3</td><td></td></tr> <tr><td>4</td><td></td></tr> </tbody> </table>	Line	Selection:	1	Serial-No: 123456/78	2		3		4		<p>Operation:</p> <p>[Menu] One menu higher</p> <p> One menu higher</p>
Line	Selection (Submenu)																											
1	Select language																											
2	Time and date																											
3	Next FT ↑																											
4	Next DT																											
5	Relais settings																											
6	Serial number ↓																											
7	Customer service info																											
Line	Selection:																											
1	Serial-No: 123456/78																											
2																												
3																												
4																												

The serial number of the CG-Controller is only an indication and can not be changed.

8.7.7 Customer service info

<table border="1" style="width: 100%; border-collapse: collapse;"> <thead> <tr> <th style="text-align: left;">Line</th> <th style="text-align: left;">Selection (Submenu)</th> </tr> </thead> <tbody> <tr><td>2</td><td>Time and date</td></tr> <tr><td>3</td><td>Next FT</td></tr> <tr><td>4</td><td>Next DT ↑</td></tr> <tr><td>5</td><td>Relais settings</td></tr> <tr><td>6</td><td>Serial number</td></tr> <tr><td>7</td><td>Customer service info ↓</td></tr> <tr><td>8</td><td>Password</td></tr> </tbody> </table>	Line	Selection (Submenu)	2	Time and date	3	Next FT	4	Next DT ↑	5	Relais settings	6	Serial number	7	Customer service info ↓	8	Password	<table border="1" style="width: 100%; border-collapse: collapse;"> <thead> <tr> <th style="text-align: left;">Line</th> <th style="text-align: left;">Display:</th> </tr> </thead> <tbody> <tr><td>1</td><td>Z726.A 10.10.2007</td></tr> <tr><td>2</td><td>Z716.A 10.10.2007</td></tr> <tr><td>3</td><td>Z772.0 10.10.2007</td></tr> <tr><td>4</td><td>Z713.A 01.10.2007</td></tr> </tbody> </table>	Line	Display:	1	Z726.A 10.10.2007	2	Z716.A 10.10.2007	3	Z772.0 10.10.2007	4	Z713.A 01.10.2007	<p>Operation:</p> <p>[Menu] One menu higher</p> <p> One menu higher</p>
Line	Selection (Submenu)																											
2	Time and date																											
3	Next FT																											
4	Next DT ↑																											
5	Relais settings																											
6	Serial number																											
7	Customer service info ↓																											
8	Password																											
Line	Display:																											
1	Z726.A 10.10.2007																											
2	Z716.A 10.10.2007																											
3	Z772.0 10.10.2007																											
4	Z713.A 01.10.2007																											

The software versions are only indications and can not be exchanged! The versions Z716 (interface card), Z772 (memory card), Z713 (I/O-module) and Z712 (LON-module) get read from the sources after a reset and taken over, when not known before.

If the interface card (line 2 = Z716), the memory card (line 3 = Z772) or the module in the optional slot (line 4) get not identified correctly, the version is not available. In this case there is a failure of a corresponding component.

Line 4 shows:

empty = no module in the slot on the left near to the memory card.2 or
Z712 LON-module or
Z713 IO-module.

Mounting and Installation Instructions

CG-Controller CGLine 400

8.7.8 Password

8.7.8.1 Activate password

Line	Selection (Submenu)	Line	Display:	Operation:
2	Time and date	1	Password:	[Menu] One menu higher
3	Next FT	2	deactivate	[←] / [→] right / left
4	Next BT	3		[↵] One menu higher
5	Relais settings ↑	4	activate n / y	
6	Serial number			
7	Customer Service info			
8	Password ■			

8.7.8.2 Deactivate password

Line	Display:	Operation:
1	Password	[Menu] One menu higher
2	activate	[←] / [→] right / left
3		[↵] One menu higher
4	deactivate n / y	

8.7.8.3 Submenu activate password

Line	Display:	Operation:
1	Password entry	[0]..[9] Entry of digit code
2	6 digit	[↵] Confirmation after entry of digit code
3	Code	
4	Password: 123456	

The digits get entered by the numeric keypad.

8.7.8.4 Menu password request

If the password protection is activated, some functions on the CG-Controller are not possible unless the password has been previously entered.

Zeile	Anzeige:	Bedienung:
1	Passwort Eingabe	[0]..[9] Entry of digit code
2	6stelliger Ziffern-	[↵] Confirmation after entry of digit code
3	Code	
4	Passwort: 123456	

For emergency cases: If you have forgotten your password, your dealer can ask for a general password for you from the manufacturer / customer service.

Mounting and Installation Instructions CG-Controller CGLine 400

8.8 Setup Luminaires

8.8.1 Automatic search of luminaires

Luminaires get searched automatically. If the luminaires still exist, they get identified as „existing“ and stay in the system.

Line Selection (Main menu)

1	Luminaire failure
2	Status luminaire
3	Test menu ↑
4	Block, release
5	Setup CG-Controller
6	Setup Luminaires ↓
7	Memory card

Line Display:

1	Automatic search
2	
3	
4	start n / y

Operation:

- [Menu] One menu higher
- [→] Selection yes
- [←] Selection no

8.8.1.1 Submenu automatic search

Line Selection (Submenu)

1	Automatic search ■
2	Add luminaire
3	Remove luminaire
4	Luminaires overview ↓
5	Change luminaire name
6	Luminaire versions

Line Display:

1	all lines
2	line 1
3	line 2
4	line 3 ↓

Operation:

- [Menu] One menu higher
- [↓] lower
- [↑] higher
- [↵] Confirm selection

8.8.1.2 Submenu automatic search All lines

When previously „all lines“ get selected, all luminaires get searched in 4 lines.

Line Display:

1	Luminaire address
2	automatic
3	allocation !!!
4	Start n / y

Operation:

- [Menu] Stop search
- [→] Selection yes
- [←] Selection no

Line Display:

1	=====
2	Search in line 1
3	05%
4	=====

Operation:

- [Menu] Stop search

Line Display:

1	Search results line
2	1 2 3 4
3	15 0 0 0
4	go on with ↵

Mounting and Installation Instructions

CG-Controller CGLine 400

8.8.2 Add luminaire

Line	Selection (Submenu)
1	Automatic search
2	Add luminaire <input type="checkbox"/>
3	Remove luminaire
4	Luminaires overview <input type="text" value="↓"/>
5	Change luminaire name
6	Luminaire versions

Line	Display:
1	Add luminaire
2	manually
3	
4	start n / y

Operation:
 One menu higher
 Selection yes
 Selection no

after selection yes:

Line	Displays:
1	enter ID
2	000 000
3	
4	<input type="button" value="↵"/> = take over

Operation:
 One menu higher
 line 2: enter ID
 Confirm selection

define address:

Line	Display:
1	define address
2	I D FA0056
3	Line 1
4	Luminaire 001

Operation:
 One menu higher
 Line 3: Select line
 Line 4: Select luminaire address
 higher
 lower
 Confirm selection

Note: By default the first free luminaire place gets displayed.

Enter / edit luminaire name (Line 1 Luminaire 001):

Line	Display:
1	ID FA0056
2	Line 1 Luminaire 001
3	Enter name:
4	Line 1 Luminaire 001

Operation:
 One menu higher
 Line 4: edit luminaire name
 Confirm settings

after return:

Line	Display:
1	-----
2	please wait
3	address allocation
4	-----

If the ID can not be found or the luminaire does not exist:

Line	Display:
1	-----
2	Wrong ID
3	on with menu
4	-----

Operation:
 One menu higher

Mounting and Installation Instructions CG-Controller CGLine 400

8.8.3 Remove luminaire

Line Selection (Submenu)

1	Automatic search
2	Add luminaire
3	Remove luminaire <input type="checkbox"/>
4	Luminaires overview <input type="button" value="v"/>
5	Change luminaire name
6	Luminaire versions

Line Display:

1	Remove	FA0056
2	Line 1 Luminaire	001
3	Line 1 Luminaire	001
4	Delete	n / y

Operation:

- [Menu] Leave menu
- Line 3: Luminaire name
- [→] next field
- [←] previous field
- [↓] lower
- [↑] higher
- [↵] Confirm selection

after return: The above menu gets displayed again.

after menu: The menu gets left.

8.8.4 Luminaires overview

Line Selection (Submenu)

1	Automatic search
2	Add luminaire
3	Remove luminaire
4	Luminaires overview <input type="checkbox"/>
5	Change luminaire name <input type="button" value="v"/>
6	Luminaire versions

Line Display:

1	-----
2	100 Luminaires
3	■■■■■
4	-----

Operation:

Line 3: Bargraph concerning 400 luminaires

Line Display:

1	Luminaires overview			
2	1	2	3	4
3	70	5	15	10
4				

Operation:

Please wait a minute

View of luminaire name and status:

Line Display:

1	Line Addr.	ID
2	1 1	FA0056 ↑
3	1 2	0BFFFF
4	2 1	0AFFF1 ↓

Operation:

- [Menu] Leave menu
- [↵] View of luminaire name and status

Line 3: Luminaire name
Line 4: Status of luminaire and charge state

- = Charge state 100%
- = Charge state less than 100%

8.8.4.1 Symbol in front of ID

- Battery is charged
- Battery is not charged
- * Luminaire failure
- ? Luminaire has got an address failure or a failure of deleting
- D Duration test active
- F Function test active

Mounting and Installation Instructions

CG-Controller CGLine 400

8.8.5 Change luminaire name

Line	Selection (Submenu)
1	Automatic search
2	Add luminaire
3	Remove luminaire
4	Luminaires overview
5	Change luminaire name
6	Luminaire versions

Line	Display:
1	Change luminaire name
2	Line 1 Luminaire 001
3	Line 1 Luminaire 001
4	change

Operation:
 [Menu] One menu higher
 Line 3: Luminaire name
 next field
 previous field
 higher (Line, luminaire)
 lower
 Confirm selection

8.8.6 Luminaire versions

Line	Selection (Submenu)
1	Automatic search
2	Add luminaire
3	Remove luminaire
4	Luminaire overview
5	Change luminaire name
6	Luminaire versions

Line	Display:
1	Line Addr. Version
2	2 1 17
3	1 2 16
4	2 1 17

Operation:
 [Menu] Leave menu
 View of luminaire name and status
 higher (endless scroll list)
 lower

8.8.7 Delete lines

Line	Selection (Submenu)
7	Delete line
8	Line name
9	Address failure list
10	Delete address failure

Line	Display:
1	Delete line
2	
3	
4	Start n / y

Operation:
 [Menu] Leave menu
 View of luminaire name and status
 yes
 no

Line	Display:
1	All lines
2	Line 1
3	Line 2
4	Line 3

Operation:
 [Menu] Leave menu
 Confirm selection
 higher
 lower

after return:

Line	Display:
1	-----
2	ended
3	on with
4	-----

Operation:
 [Menu] Leave menu
 back

8.8.8 Line names

Line	Selection (Submenu)
7	Delete line
8	Line name
9	Address failure list
10	Delete address failure

Line	Display:
1	-----
2	Line name
3	Line 1 = line 1
4	-----

Operation:
 brief note

Line	Display:
1	Line 1
2	Line 2
3	Line 3
4	Line 4

Operation:
 [any button] Leave menu

The line names only get displayed in this menu. They get defined in the PC-Software.

Mounting and Installation Instructions

CG-Controller CGLine 400

8.8.9 Address failure list

When luminaires with an address failure exist this can be seen in the main screen, line 3 'address failure' and in the menu 'Setup luminaires' the menu level 'address failure list'. All luminaires with an address failure are shown in a scroll list.

Line Selection (Submenu)

7	Delete line
8	Line name
9	Address failure list
10	Delete address failure

Line Display:

1	-----
2	4 luminaires
3	-----
4	-----

Operation:

Brief note: Number of luminaires with an address failure

Line Display:

Line	Addr.	ID
1	?	?FA0056
3	?	?0BFFFF
4	?	?0AFFF1

Operation:

[Menu] Leave menu
 [↓] View of luminaire name and status
 [↑] higher (endless scroll list)
 [↓] lower

8.8.10 Delete address failure

When luminaires with an address failure exist that means that the CG-Controller found luminaires with ID's during the process of searching, but the addresses have not been overtaken successfully during address allocation by the controller. With the help of this menu level it is possible to delete the address failure, automatically. Previously, a faultless connection should exist.

Line Selection (Submenu)

7	Delete line
8	Line name
9	Address failure list
10	Delete address failure

Line Display:

1	Allocate luminaires with
2	address failure again?
3	
4	n / y

Operation:

[Menu] Leave menu
 [→] yes
 [←] no

Line Display:

1	=====
2	Send Data --> Luminaire
3	25% line 1
4	=====

Operation:

[Menu] cancel

8.9 Memory card

8.9.1 Display log book

Line Selection (Submenu)

1	Display log book
2	Display log book of sum
3	Delete log book
4	Configuration -> SD
5	Configuration <- SD
6	Configuration from PC Sof.

Line Display

1	24.05.2007 11:31:44
2	Nr.: 000 128
3	Luminaire failure line 1
4	← → ↓ ↑ select

Operation:

[Menu] One menu higher
 Line 3: Event
 [↑] previous event
 [↓] next event
 [→] last event
 [←] first event
 [1] + 10 events
 [2] - 10 events

The content of line 4 gets changed with approx. 1 Hz when further details exist (sum inputs after FT and DT).

Mounting and Installation Instructions

CG-Controller CGLine 400

8.9.2 Display log book of sum entries

Line	Selection (Submenu)
1	Display log book
2	Display log book of sum <input checked="" type="checkbox"/>
3	Delete log book
4	Configuration -> SD
5	Configuration <- SD
6	Configuration from PC Sof.

Line	Display
1	Line Addr. ID
2	1 1 FA0056
3	1 2 BA0000
4	Details with ↵

Operation:
 [Menu] One menu higher
 Shows details of the selected entry

↑ ↓ Selection, when more than 2 entries exist. The blinking cursor in line 1 shows the selected entry.

Display of details:

Line	Display
1	Line 1 Addr. 001 FA0056
2	Line 1 Luminaire 001
3	Luminaire failure
4	back with ↵

Operation:
 [Menu] One menu higher
 Line 2: Luminaire name
 Line 3: Event
 back

8.9.3 Delete log book

Line	Selection (Submenu)
1	Display log book
2	Display log book of sum
3	Delete log book <input checked="" type="checkbox"/>
4	Configuration -> SD
5	Configuration <- SD
6	Configuration from PC Sof.

Line	Display
1	Delete log book
2	
3	
4	n / y

Operation:
 [Menu] One menu higher
 Confirm selection
 Selection yes
 Selection no

Note: If the log book entries get deleted without saving them on another medium before, the log book has to be kept acc. to VDE 0108 T100 in another way!

8.9.4 Configuration -> SD

Line	Selection (Submenu)
1	Display log book
2	Display log book of sum
3	Delete log book
4	Configuration -> SD <input checked="" type="checkbox"/>
5	Configuration <- SD
6	Configuration from PC Sof.

Line	Display
1	Configuration -> SD
2	write on SD
3	
4	n / y

Operation:
 [Menu] One menu higher
 Confirm selection
 Selection yes
 Selection no

after select yes:

Line	Display
1	Configuration -> SD
2	
3	■■■■■■
4	

Operation:
 Line 3: Bargraph

The EEPROM gets saved in CONFIGG.DAT.

8.9.5 Configuration <- SD

Line	Selection (Submenu)
1	Display log book
2	Display log book of sum
3	Delete log book
4	Configuration -> SD
5	Configuration <- SD <input checked="" type="checkbox"/>
6	Configuration from PC Sof.

Line	Display
1	Configuration <- SD
2	read from SD
3	
4	n / y

Operation:
 [Menu] One menu higher
 Confirm selection
 Selection yes
 Selection no

Mounting and Installation Instructions CG-Controller CGLine 400

after selection with yes:

Line	Display
1	With luminaire update?
2	
3	
4	n / y

When selection is confirmed with yes, the addresses of the luminaires will be reprogrammed. When selection is confirmed with no, a luminaire configuration is read from the memory card.

In this case there is the risk that the existing physical luminaires are not conform to the read configuration. Luminaires existing per SD-configuration get a new address, that means the old one will be deleted and the new one will be programmed. If nothing was changed to the physical constellation between saving and reading of the configuration, the answer here can be 'no'.

than:

Line	Display	Operation:
1	Configuration <- SD ■■■■■■	Line 3: Bargraph
2		
3		
4		

after reading luminaires get configured:

Line	Display
1	-----
2	Configured Luminaire
3	Line 3 Luminaire 032
4	-----

8.9.6 Configuration made by the PC Software

After the input of a SD it will be checked if a new configuration of the PC software exists.

Line	Selection (Submenu)
1	Display log book
2	Display log book of sum
3	Delete log book
4	Configuration -> SD
5	Configuration <- SD
6	Configuration from PC Sof. ■

Line	Display
1	-----
2	New config. from PC
3	transferred?
4	-----

Operation:

- Menu One menu higher
- Confirm selection
- Selection yes
- Selection no

selection with yes:

Line	Display	Operation:
1	Configuration <- SD ■■■■■■	Line 3: Bargraph
2		
3		
4		

than:

Line	Display
1	-----
2	Configured luminaire
3	Line 3 Luminaire 032
4	-----

than:

Line	Display	Operation:
1	write on SD ■■■■■■	Line 3: Bargraph
2		
3		
4		

Mounting and Installation Instructions

CG-Controller CGLine 400

9 LED displays

The CG-Controller communicates visible codes by means of 3 LEDs. These are definite by their position and colour.

9.1 LED displays operation, test and failure

9.1.1 Control module software (LED displays)

9.1.1.1 Operation, green LED

The control panel of the CG-Controller CGLine shows the „Operation mode“ state with a green LED.

- LED green on = The entire emergency lighting system is ready for operation.

9.1.1.2 Test, yellow LED

The control panel of the CG-Controller CGLine shows the „Test“ state with a yellow LED.

- LED yellow on = One or more luminaire are in test mode.

9.1.1.3 Failure, red LED

The „Failure“ state is indicated by a red LED.

- LED red on = one or more luminaires are reporting a failure.

LED-displays

No.:	One or more self contained luminaires	Operation LED green on	Test mode LED yellow on	Failure LED red on
1	Functiontest		X	
2	Durationtest		X	
3	Blocked			X
4	Operation	X		
5	Battery mode			X
6	Communication failure			X
7	Lamp defect			X
8	Charging failure			X
9	Test failure			X
10	CG-Controller failure			X
11	Charge state too low for testing			X

Notes:

- A battery operation is indicated as a failure, except during a FT or DT.
- If a failure occurs, no „Operation“ is displayed.
- The yellow LED can be active together with the green or red one.

Mounting and Installation Instructions

CG-Controller CGLine 400

10 Memory card

The CG-Controller CGLine needs a 32 MB SD-card at least. An operation without SD-card is not possible. When the SD card is not inserted in the CG-Controller for a short time it is ensured that max. 11 log book entries are saved in the EEPROM.

Luminaire names are only saved on the SD, so when the SD card is not inserted in the CG-Controller the names will not be displayed.

10.1 SD files

The following files exist on the SD:

TEXTE.DAT 400 luminaire names + 4 line names + 1 project names

ADDRESS.DAT Luminaire ID's

CONFIGCG.DAT Configuration CG-Controller CGLine 400

LOGBOOK.DAT Log book

LUMCFG.DAT Luminaire-configuration (Information can be generated from our customer service).

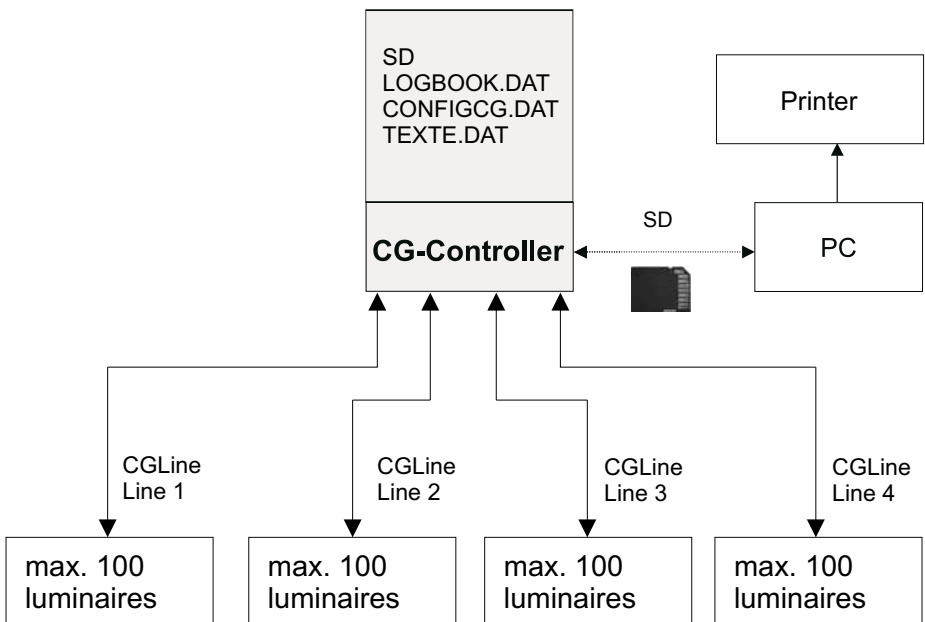

Mounting and Installation Instructions

CG-Controller CGLine 400

11 I/O-module for connecting a key-operated switch / Display-LED's (F3-remote indication)

Optional an I/O-module is available to connect an key-operated switch (F3-remote indication) to the CG-Controller CGLine 400 with the following part no.: 400 71 347 985. The I/O-module is delivered as an installed circuit board in the CG-Controller. The connection of an F3-remote indication makes it possible that all luminaires of all lines can be blocked by a key switch during shut-down times. **Attention! To release blocked luminaires mains supply is strictly necessary! The release during a mains failure is not possible.** The block input is equipped with a differential loop monitoring (short circuit, interruption reconnaissance). For blocking a 1 KOhm resistance at the F3 remote indication (key-operated switch) must be connected in parallel to S1/S2. Furthermore, the entire state is shown on the F3-remote indication by the LED's:

- Operation mode (green LED)
- Min. 1 luminaire in one line runs in battery mode or test mode (yellow LED)
- Sum failure (red LED)

Connection diagramm: Controller -> F3-remote indication

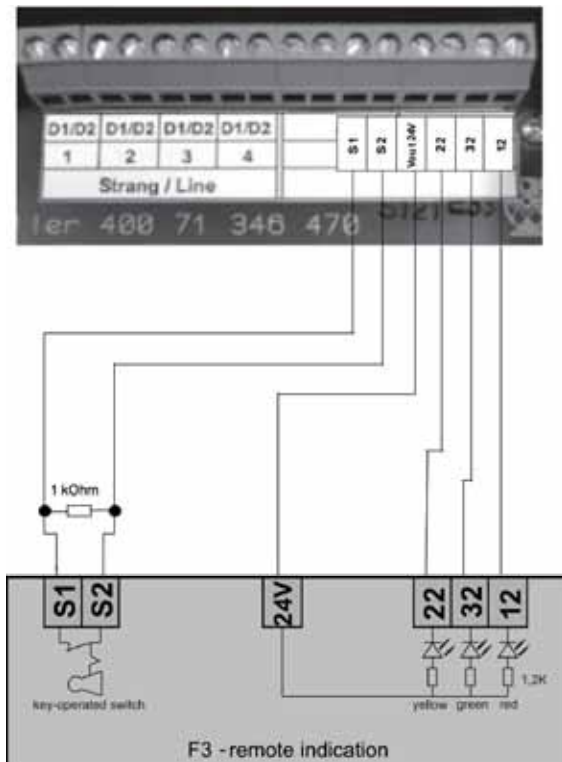

Attention: For operation of an I/O-module a CG-Controller with SD-card is required. An operation with a CG-Controller with SMC card is **not** possible!

Mounting and Installation Instructions

CG-Controller CGLine 400

Note: It is not allowed to connect relais instead of LEDs!

Mounting and Installation Instructions

CG-Controller CGLine 400

Mounting and Installation Instructions

CG-Controller CGLine 400

CEAG Notlichtsysteme GmbH

Senator-Schwartz-Ring 26
59494 Soest
Germany

Tel: +49 (0) 2921/69-870
Fax: +49 (0) 2921/69-617
Web: www.ceag.de
Email: info-n@ceag.de

Cooper Safety

Jephson Court
Tancred Close
Royal Leamington Spa
Warwickshire CV31 3RZ
United Kingdom

Tel: +44 (0) 1926 439200
Fax: +44 (0) 1926 439240
Web: www.cooper-safety.com
Email: enquiries@cooper-safety.com

400 71 860 016(F)/XXX/11.10/WK